

**REQUEST FOR PROPOSAL**  
**FOR**  
**SUPPLY, INSTALLATION & COMMISSIONING OF**  
**SECURITY & SURVEILLANCE SYSTEM AT**  
**VARIOUS JAILS OF HARYANA**  
**ON**  
**BUILD OWN**  
**OPERATE AND TRANSFER (BOOT)MODEL**



RFP no. Hartron/Proj/CCTV HARYANA JAIL/ 2010-11/\_\_\_\_\_

Dated: \_\_\_\_\_

---

**Haryana State Electronics Development Corporation Limited**

S.C.O. 111-113, Sector 17-B, Chandigarh – 160017 (India)  
Ph. 0172-2704922, 2710743, 2714302, 2722961-62, Fax-0172-2720113  
Website: [www.hartron.org](http://www.hartron.org)

## IMPORTANT INFORMATION

<b>Non-refundable RFP document cost</b>	Rs.5000/- through demand draft/bankers pay order from a scheduled bank, drawn in favour of "Haryana State Electronics Development Corporation Ltd", payable at Chandigarh. Or the said RFP document can also be downloaded from Hartron website i.e. <a href="http://www.hartron.org">www.hartron.org</a> . Such bidders are required to submit the non refundable RFP document cost alongwith the EMD
<b>Sale of RFP document</b>	9.00 am to 4.00 pm on all working days starting from 23.11.10 till 22.12.10
<b>EMD</b>	Rs. 5,00,000/- in the form of Demand Draft in favour of HARTRON payable at Chandigarh from a scheduled bank.
<b>Site Visits</b>	Bidders are required to conduct the site visits as per the following schedule before submitting their proposals. The bidder can accordingly plan their visits as per schedule given in the RFP for 01.12.10, 02.12.10, 03.12.10, 04.12.10 and 06.12.10.
<b>Pre bid conference</b>	11.30 am on 09.12.10 in Haryana State Electronics Development Corporation Limited. S.C.O. 111-113, Sector 17-B, Chandigarh
<b>Last date for submission of bids</b>	Up to 2:30 P.M. on 23.12.10 in Haryana State Electronics Development Corporation Limited. S.C.O. 111-113, Sector 17-B, Chandigarh
<b>Opening of Pre-Qualification bids</b>	3:30 P.M. on 23.12.10 in Haryana State Electronics Development Corporation Limited. S.C.O. 111-113, Sector 17-B, Chandigarh

<b>Language of the bid</b>	This bid should be filed in English language only. If any supporting documents submitted are in any language other than English, translation of the same in English language is to be duly attested by the bidder.
----------------------------	--

# INDEX

1.	INTRODUCTION.....	8
	1.1 SYSTEM OBJECTIVE-.....	8
	1.2 ARCHITECTURE.....	9
2.	SCOPE OF WORK.....	11
	2.1 SCOPE OF SUPPLY.....	13
	2.2 SCOPE OF INSTALLATION, COMMISSIONING & SYSTEM INTEGRATION.....	14
	2.3 FACILITY MANAGEMENT.....	19
	2.4 SCOPE OF TRAININGS.....	20
	2.5 SCOPE OF ACCEPTANCE TESTING.....	21
	2.6 ADDITIONAL EXPANSION.....	22
3.	TECHNICAL REQUIREMENT.....	24
	3.1 GENERAL.....	24
	3.2 SUGGESTIVE CCTV LAYOUT DIAGRAM.....	26
	3.3 BILL OF MATERIAL.....	27
4.	ELIGIBILITY CRITERIA.....	42
	4.1 BIDDERS GENERAL QUALIFICATION.....	42
	4.2 MINIMUM ELIGIBILITY CRITERIA.....	42
5.	BIDDING PROCESS.....	47
	5.1 ADVICE TO THE BIDDERS.....	47
	5.2 SALE OF BID DOCUMENT.....	47
	5.3 VALIDITY OF THE BID.....	47
	5.4 TRANSFERABILITY OF THE RFP DOCUMENT.....	47
	5.5 MISPLACEMENT OF THE RFP DOCUMENT.....	47
	5.6 PRE BID DISCUSSIONS, PLACE, TIME AND DATE:.....	48
	5.7 ADDRESS AT WHICH THE BIDS ARE TO BE SUBMITTED:.....	48
	5.8 LAST TIME AND DATE FOR RECEIPT OF BID :.....	48
	5.9 PLACE, TIME AND DATE OF OPENING OF PRE-QUALIFICATION BID:.....	48
	5.10 EARNEST MONEY DEPOSIT (EMD).....	48
	5.11 PRE-BID CONFERENCE.....	48
	5.12 PROCEDURE FOR SUBMISSION OF THE BID.....	49
	5.13 DOCUMENTS COMPRISING THE BIDS.....	51
	5.14 OPENING OF BIDS AND PROCEDURE OF EVALUATION.....	54
	5.15 CRITERIA FOR REJECTION OF BIDS.....	58
	5.16 ACCEPTANCE OF THE BID.....	60
	5.17 CROSS CHECKING.....	60
	5.18 ABSENCE OF SPECIFICATIONS.....	60
	5.19 COST INVOLVED IN TENDERING.....	60
	5.20 AMENDMENT IN THE RFP DOCUMENT.....	60

---

5.21 WITHDRAWAL OF BID PROPOSAL .....	61
5.22 RIGHT TO NEGOTIATE .....	61
5.23 CONTRACT AGREEMENT .....	61
5.24 EARNEST MONEY REFUND .....	61
5.25 LETTER OF INTENT AND PERFORMANCE BANK GUARANTEE .....	62
5.26 RIGHT TO VARY QUANTITIES.....	63
5.27 RIGHT TO ACCEPT ANY BID AND TO REJECT ANY OR ALL BIDS .....	63
5.28 CHANGES IN TECHNICAL SPECIFICATIONS AND PRICE BID.....	63
5.29 PROPRIETARY RIGHTS.....	64
5.30 PATENT RIGHTS .....	64
5.31 ADDITIONAL INFORMATION/CLARIFICATION .....	64
6. TERMS & CONDITIONS OF CONTRACT .....	66
6.1 USE OF RFP DOCUMENT AND OTHER INFORMATION .....	66
6.2 CHANGE IN THE MINIMUM SPECIFIED WORK.....	66
6.3 CHANGES IN CONTRACT AGREEMENT .....	67
6.4 PROJECT MILESTONES .....	67
6.5 RESPONSIBILITIES OF SUCCESSFUL BIDDER .....	68
6.6 RESPONSIBILITIES OF TENDERER.....	69
6.7 PRICE FALL.....	70
6.8 INSPECTION/TESTS OF THE ITEMS/EQUIPMENTS.....	70
6.9 SITE VISIT .....	71
6.10 WARRANTY .....	71
6.11 FACILITY MANAGEMENT AND SERVICE LEVEL AGREEMENT .....	72
6.12 THIRD PARTY AGENCY .....	75
6.13 SPARES .....	75
6.14 DISPATCH DOCUMENTS.....	75
6.15 CONDITION OF ITEMS SUPPLIED.....	76
6.16 ACCEPTANCE TESTS.....	76
6.17 PAYMENT SCHEDULE .....	78
6.18 HANDING OVER: .....	80
6.19 SUB-CONTRACTING OF THE PROJECT .....	81
6.20 CHANGE IN COMPANY STRUCTURE .....	81
6.21 COMPLIANCE WITH LAWS, PERMITS.....	82
6.22 LIABILITY INSURANCE.....	82
6.23 FORFEITURE OF EARNEST MONEY .....	82
6.24 FORCE MAJEURE .....	83
6.25 TERMINATION OF THE CONTRACT .....	83
6.26 CONSEQUENCES OF TERMINATION .....	84
6.27 INSURANCE OF ITEMS.....	85
6.28 ARBITRATION .....	86

<b>6.29 ACQUAINTANCE WITH ALL CONDITIONS</b> .....	<b>87</b>
<b>6.30 LIMITATIONS OF LIABILITY</b> .....	<b>87</b>
<b>ANNEXURE-1</b> .....	<b>89</b>
<b>ANNEXURE-II</b> .....	<b>90</b>
<b>PROFORMA-1</b> .....	<b>93</b>
<b>PROFORMA-2</b> .....	<b>96</b>
<b>PROFORMA-3</b> .....	<b>97</b>
<b>PROFORMA-4</b> .....	<b>98</b>
<b>PROFORMA-5</b> .....	<b>99</b>
<b>PROFORMA-6</b> .....	<b>100</b>
<b>PROFORMA-7</b> .....	<b>101</b>
<b>PROFORMA-8</b> .....	<b>102</b>
<b>PROFORMA-9</b> .....	<b>103</b>
<b>PROFORMA-10</b> .....	<b>105</b>
<b>PROFORMA-11</b> .....	<b>106</b>
<b>PROFORMA-12</b> .....	<b>107</b>
<b>PROFORMA-13</b> .....	<b>109</b>
<b>PROFORMA-14</b> .....	<b>112</b>

\*\*\*\*\*

**Section – 1**  
**INTRODUCTION**

## 1. Introduction

- a) Haryana Prison department intends to have security & Surveillance monitoring system in all the State Prisons (Jails) across the state of Haryana.
- b) Prison department is looking for a solution using IP CCTV systems on “Build Own Operate & Transfer (BOOT) model” for the security and surveillance of the jail premises with a specific focus on the sensitive areas including all entry and exit points, parking lots, dining halls, corridors, visitor areas, etc. The system must be capable of monitoring from the central room in the respective jails as well as selected monitoring from the head office at sector-14, Panchkula.
- c) The bidders are required to propose wireless network as backbone.

### 1.1 System objective-

The objective of the system is to create a robust wireless infrastructure as backbone with essential focus on video surveillance, voice communication and on line data transaction. It is to be designed to achieve/provide having the following facilities but not limited to:

- a) Continuous visual coverage of the entire Jail Complex for close monitoring of the jails premises both in active & passive manner.
- b) Monitor inmate activity to spot suspicious inmate activity, and prevent prison incidents.
- c) Provide visual evidence in terms of Archived surveillance footage for investigations of prison incidents.
- d) Maintain order in common areas where large groups of inmates converge, such as dining and recreational areas, using multiple security cameras.
- e) Remote video monitoring and data transfer to
  1. Help in analyzing incidents of violence.
  2. Help in prevention of smuggling of drugs into the Jail Complex by the inmates.

3. Help in analyzing officer behavior towards inmates so as to prevent further misconduct.

The list of jails to be covered under this project is enclosed at Appendix I.

### 1.2 Architecture

The required security and surveillance system must comprise of the following:

- (a) Wireless-IP Network in Point-to-Point/Multipoint setup to be proposed in both the bands i.e. 2.4 Ghz & 5.8 Ghz. band.
- (b) The solution so designed should be tamper proof so as to mitigate any attempt to tamper with the security equipments.

### 1.3 Site visit

The bidders are required to conduct the site survey of each jail as per the schedule given as under.

Sr. No.	Name of Jail	Date for site visit
1.	D.J. Yamuna Nagar	01.12.10
2.	C.J. Ambala	01.12.10
3.	D.J. Karnal	01.12.10
4.	DJ Kurukshetra	01.12.10
5.	D.J. Sonapat	02.12.10
6.	Rohtak	02.12.10
7.	D.J. Bhiwani	02.12.10
8.	D.J. Faridabad	03.12.10
9.	D.J. Gurgaon	03.12.10
10.	Jajjhar	03.12.10
11.	D.J. Narnaul	03.12.10
12.	C.J. Hisar	04.12.10
13.	B.I. & J. Jail Hisar	04.12.10
14.	D.J. Jind	04.12.10
15.	D.J. Kaithal	04.12.10
16.	D.J. Sirsa	05.12.10

During, the site visits, the bidders are required to understand the surveillance system requirement so as to work out a solution for each jail in consultation with respective Jail Superintendents. Based on the site visits/surveys, the bidders are required to work out the bill of material, which will be further evaluated during the technical evaluation.

\*\*\*\*\*

## **Section – 2**

### **Scope of Work**

## 2. Scope of work

The minimum specified scope of work to be undertaken by the bidder is to be performed as per the specifications and conditions mentioned in the different parts of this document, any further amendments issued in this regard and the contract to be signed by the successful bidder subsequently.

(i) Scope of work includes design and engineer a wireless CCTV surveillance system for respective jails based on the Build Own Operate and Transfer (BOOT) model for five years. The broad scope of work is defined as under:-

1. The bidder shall provide solution for all the jails and include any missing item(s) notwithstanding the detailed Bill of Material (BOM) given in RFP for the successful end to end implementation.
2. The broad system architecture include network connectivity, IP based cameras for surveillance control equipment and back end equipment.
3. Supply, installation and commissioning of requisite hardware and software for the CCTV surveillance system to connect the central office locations of respective Haryana jails mentioned at annexure 1 of this RFP. The camera so proposed must have a Customer Premises Equipment (CPE) which will communicate with access point and shall support minimum data rate of 10mbps for video and voice.
4. All the jails have appropriate arrangement for the backup power supply through Gensets. However in order to ensure uninterrupted power supply, adequate capacity UPS with four hour back up has been planned for the respective control rooms at each jail. The bidder is further required to provide adequate capacity UPS with one hour back up for the cameras installed at important locations. The said locations shall be decided by the bidder in consultation with the Superintendent Jails/concerned officer of the respective jail.
5. The System should facilitate viewing of live and recorded images and controlling of all cameras by the authorized users. All recordings must be done minimum at 4 CIF 25/30 FPS. System

should provide inter-operability of hardware, Operating System, software, networking, printing, database connectivity, reporting, and communication protocols. The system installed at each jail should be capable of providing Thirty day (30) recording.

6. The system installed at each jail should have the facility of remote viewing by the Director General Prison from his office at sector 14 in Panchkula through the Haryana SWAN connectivity already made operational at each jail by Hartron.
7. This system at each jail must be scalable and allow for unlimited expansion of the IP CCTV system or other equipment/solution in subsequent phases on procurement of requisite licenses, components, solution etc.
8. Earthing, Digging, Filling and ensuring to make the site to its original condition will be the responsibility of the System Integrator including supply and installation of poles, housing & any additional fixtures that may be required for the implementation of the system at all the sites.
9. The bidder for successful completion of project shall provide all the accessories, brackets, poles, various type of cables conduits, ducts etc. and fixtures required for each location. All the fitting should be under ground where ever possible
10. The requirement mentioned in this RFP calls for a complete working system and not components thereof. Bids must be complete with all equipment and required accessories along with necessary power systems including standard Un-interrupted Power Supply for the entire equipment, video connectors, patch connectors, patch leads, mounting and fitting hardware, plugs, sockets and any hardware/software, etc. as required for complete installation of the System under this contract. The minimum suggestive technical specifications including suggestive Bill of Material is given in Section-3 of this RFP.
11. The bidder is required to take all necessary approvals for the frequency, Right of way (if required) under this project. However,

Prison department shall provide all the facilitations to the successful bidder for early permissions.

12. The successful bidder is required to conduct a detail site survey of the jails as per the schedule given in the important information at pg. no. 2 of this RFP and shall submit the project plan that should include the following:

- (a) Site survey report, connectivity diagrams for all the jail sites.
- (b) Document giving the details of methodology using the best practices of the industry and optimized configuration for network devices to be installed and configured under this project as well as details about methodology to be used for facility Management, and Service Level Management.

13. During the BOOT period of five years, the successful bidder is required to provide the facility management services which include operations, maintenance and management of the entire project for end to end services. The bidder may also quote for facility management for sixth and seventh year and decision in this regard shall be taken by HARTRON in consultation with Prison Department, Haryana.

## **2.1 Scope of Supply**

- (i) The successful bidder shall supply all hardware which includes network equipment, IP CCTV system, camera hardware, servers, storage, work stations and requisite software as per specifications & configurations mentioned in Section-3 of this RFP. Further, the successful bidder must not bid/supply any equipment that is likely to be declared end of sale within one year from the date of supply. The successful bidder would be required to replace all such equipment with latest and at least of equivalent configuration without any financial implications. The successful bidder should submit the confirmation of these conditions in OEM's letterhead.
- (ii) All the active components (Cameras, Camera lenses, DVR/NVR,

Storage, Centralised Video Management Software/solution, Intelligent Video management software etc) components need to be of the reputed make across all the jails to be connected under this RFP to ensure standardization and Certification from the original manufacturers.

- (iii) The successful bidder shall be responsible for end-to-end implementation of connectivity of all the locations under this RFP and shall quote and provide/ supply any item(s) of latest make and model not included in the bill of materials, but required for successful implementation and commissioning of the system as well as its management. For such item(s), which have not been quoted by the successful bidder in the bid, but are required for successful completion of the project, the tenderer shall not pay for the same.
- (iv) The supply of all the installation material/accessories/ consumables necessary for the installation of the systems.
- (v) The successful bidder shall provide patches and updates of OS free of cost for 5 (five) years for the items quoted under this project.
- (vi) The required networking equipment for end to end connectivity shall also be provided by the bidder at each location.
- (vii) The complete ownership of the network proposed on wireless will that be of Prison department Haryana. However complete maintenance will be in the scope of the bidder including rectification of minor or major faults/breakages in the wireless equipment.

## **2.2 Scope of installation, commissioning & system integration**

- (i) The scope of installation, commissioning & system integration shall mean to install, configure and integrate the following (but not limited to), adhering to essential security measures.
  - a) Carry out installation of active components, passive components and accessories supplied as per standards for successful integration and implementation of the systems at each jail connected under this RFP.

- b) Configuring and fine-tuning of subsystems to achieve overall optimal network performance and highest security.
- c) Cameras shall be installed at the various critical locations i.e. Boundary Wall, Guard Towers, Grounds, Visitor Area, Entry/Exit Doors. Any more locations should be suggested by bidder after the detailed site survey of each jail.
- d) ***The CCTV cameras so supplied should be enclosed in the metallic protective covering so that the same can not be tampered with by the prison inmates.***
- e) ***The camera so supplied under this project should have a wide coverage so as to ensure that there are no blind spots during surveillance. The cameras should be installed in such a manner that each camera should be in the viewing area of another camera so as to avoid any tampering by the prison***
- f) All the cameras are connected to wireless CPE which in turn is communicating with wifi Access Point (AP)
- g) CPE shall have enough gain to provide strong signals for the video & audio communication
- h) Wireless Communication should be fully secure and shall support 128-bit encryption or better
- i) All Cameras shall support at least 1280 x 720 (720p) resolutions and shall support 25/30 FPS.
- j) Minimum bit-rate of streaming shall be 2 Mbps
- k) All the AP's in jail premises are connected through wireless or wired medium with Local Control Room.
- l) Access Point shall be placed in such a way that it cover the entire jail area which is under surveillance. Associated planning and diagrams of placement of Access Points shall be provided by bidder

- m) Local Control Room shall be established in order to view and manage the complete surveillance system
- n) Recording shall be done at minimum 4CIF 25/30 FPS and storage system shall have the capacity to store the recordings for minimum of Thirty (30) days.
- o) Recording shall be tamper proof and access to the recording shall be restricted by implementing user based security
- p) Pre-buffer and Post-buffer recording mode shall be supported.
- q) Video Analytics shall be used to generate the alarms and should act as the basis for the automation of the complete surveillance system
- r) Alarms should be in the form of: e-mail, sound alarms, SMS. Alarms should be configurable for each individual event
- s) Video Loss Alarms shall be supported for all the cameras
- t) Once a alarm is detected the system shall provide visual or sound indication to the operator through both a text over lay on the screen and alarm buzzer sound
- u) Central Streamer shall be supported. Only one video stream from the camera shall be preferred to ensure optimum use of bandwidth
- v) Video Management software shall support the streaming over mobile
- w) Software licenses for the following modules shall be provided:
  - Live View & Video Management Software
  - Recording Software
  - Video Analytics Software
- x) There shall be no license restriction on the number of users

- y) Software License provided shall be sufficient for all the cameras in all the jails.
- z) There shall be no recurring cost for any hardware/software license for any equipment.
- aa) Complete Video Management and Video Analytics software should be user friendly. Bidder might have to demonstrate the software with all the functionalities desired.
- bb) Power is given to the cameras through local utility power supply/Gensets already available at each jail. In addition to this, the bidder is also required to provide back up power supply through UPS with one hour back up to cameras installed at important locations.
- cc) Power cable and laying out from the common AC power points provided by Jail Authorities shall be in scope of bidder.
- dd) All the control room equipments shall have a UPS power back up of minimum 4 hrs.
- ee) 24 Port Gigabit Network switch shall be provided at the control rooms to aggregate the video & audio data from the various access points. There shall be minimum 2 uplink Gigabit ports for the WAN communication.
- ff) The successful bidder shall make sure for enough manpower to provide the support 24 x 7 for all jails for the entire warrant period of 5 years
- gg) Complete system shall have a warranty for 5 years (first 3 years inbuilt into the proposal cost and last 2 years AMC cost shall be provided in the price bid)

- hh) Jail Authorities may decide at a later time to have a centralized control room to monitor all the jails of Haryana. System proposed by bidder shall be scalable to support such Architecture. Bidder may be asked to demonstrate the same.
- ii) All patches and updates shall be provided by the successful bidder during the currency of the contract.
- (ii) Carrying out all general tests such as Power on test on delivery, pre-installation checks to ensure correct connections, completeness of system documentation etc.
- (iii) The successful bidder shall not cause any damage to Government buildings/other premises/property, if any damage occurs, the successful bidder will perform restoration. Trenches, path/road cutting, etc. will be back-filled and restored to the original condition immediately after laying of the conduit/cable/erection of mast etc. The successful bidder if required shall also plug conduits and entrance holes with suitable sealing material, where the cable has been laid.
- (iv) The system shall be subjected to inspection at various stages. The successful bidder shall follow all Safety Regulations and practices.
- (v) Bidders shall spell out various tests that are being proposed to be carried out for demonstrating the functionality of the solution.
- (vi) The Successful Bidder shall provide warranty for all the components including hardware, software, etc. as per RFP for a period of Five Years from the date of the issuance of Final Acceptance Certificate. Network active components shall have a warranty of 5 years and passive components shall have a performance warranty of 20 years. Any delay for acceptance caused by the successful bidder will result in automatic extension of the total warranty period as well as the facility management period by the same period.
- (vii) The bidder shall further provide the rates for the comprehensive AMC of the entire equipment including software supplied under this RFP for Sixth and Seventh year and shall be considered in the commercial

evaluation.

- (viii) The requisite connectivity shall be arranged by successful bidder. The successful bidder shall be responsible for the commissioning and maintenance of the entire wireless connectivity. .
- (ix) **Civil works**: The requisite space for the installation of the cameras and other related equipment shall be provided by Prison department at all jails.
  - a) The successful bidder shall have to undertake the cabling/erection of mast/fixing of poles etc. as per the requirement.
  - b) Civil works including digging etc., if any, required for providing end to end connectivity will be the responsibility of the successful bidder.
  - c) The successful bidder shall be responsible for restoring the areas to its original shape wherever, the digging if any has been undertaken by him for end to end implementation of the system.
- (x) **Electrical works**:
  - a) Electrical cabling upto the equipment to be kept at each location, rack etc. as the case may be shall be the responsibility of the successful bidder. However the power shall be provided by the prison department.
  - b) Carry out installation and configuration of the electrical components as per the standards.
- (xi) The quantity of passive items if any shall be verified by the concerned official at each site.

### **2.3 Facility Management**

- a) The successful bidder, will undertake to completely manage and maintain the said equipment/infrastructure installed and commissioned at these sites as mentioned at Annexure-1 under this RFP for a minimum period of five years after the clearance of Final Acceptance Test of the project by Technical Committee constituted by the Prison Department and Hartron and with effect from the date on which acceptance certificate for successful commissioning of the system is issued by HARTRON and Prison department jointly. During the said

period of undertaking, the successful bidder will be responsible for the smooth working of the total system installed at the locations under this project and to ensure minimum 99% uptime. This task of management of project will be termed as 'facility Management' in the rest of the document. HARTRON in consultation with the Prison department may extend the facility management period for sixth and seventh year.

- b) Successful bidder shall depute minimum three technical professional having requisite qualifications and experience for operation and maintenance of CCTV systems at each jail. In addition to the said requirement, the bidder is also required deploy four more such technical professionals as reserve. One such reserve professional out of four shall be stationed at each range Headquarter i.e. Ambala, Rohtak, Gurgaon and Hisar.
- c) These technical professional shall be deployed on eight hourly shifts and shall be under the direct administrative control of the concerned jail superintendent. These professional shall be responsible to operate, configure, maintain and manage the CCTV surveillance system during the facility Management period. They will either be stationed at the Control Room or at any other place in respective control room as per the requirement of prison department. The successful bidder shall provide a mobile phone at his cost to each of this staff so that the Prison personnel can reach them for fault rectification and other related services.
- d) The cost, if any, for undertaking the facility Management as specified at (a) of this section, should be specified separately for each year including sixth and seventh year.

## **2.4 Scope of Trainings**

Detailed training for operation and management of equipment/infrastructure to minimum 5 officials at each installation location to the satisfaction of the Prison department and shall be mandatory so that the officials of Prison

department can handle the equipment/infrastructure, once the facility management period is over.

- (i) The successful bidder shall impart hands on training with detailed course material on the installed equipment covering at least the following:-
  - a) Configuration and their operation of CCTV Equipment, Cameras, storage devices and other equipment etc. supplied under the project.
  - b) Introduction to Computers, servers, their Configuration and Operations
  - c) Network video management software etc.
  - d) Trouble shooting and preventive maintenance
- (ii) The training shall be carried out for a period of two weeks as mentioned above for which the detailed training programme shall be submitted by the successful bidder. All the expenses towards training excluding related to travel, boarding, lodging of the trainees so deputed by the Prison department shall be borne by the bidder.
- (iii) In addition to the above the technical manpower deployed by the bidder at each jail shall also provide hand on training to the concerned staff at each jail on a continuous process.

## **2.5 Scope of Acceptance Testing**

- (i) The acceptance tests for the sites shall be carried out in accordance to the methodology mentioned at clause no 6.16 of this document.
- (ii) The above said acceptance test shall be conducted at each location by a committee comprising of officers from Prison department and HARTRON, and Head of the respective site or any officer or person and duly authorized by the tenderer.
- (iii) Prisons Department alongwith Hartron will prepare detailed Acceptance Testing Plan (ATP) including test parameters, commitments etc. which shall be acceptable to the successful bidder for each of the site components. The test parameters, commitments etc. as decided & approved by the tenderer shall be final and binding on the successful

bidder.

- (iv) The successful bidder shall ensure that the cabling and crimping/termination is done in accordance with the industry standards and supported by the Original Equipment Manufacturer (OEM) fully tested and certified for operations for a minimum period of 20 years.
- (v) All the functionality, features and configuration relevant to his project shall be documented and demonstrated by the successful bidder to the tenderer.

## **2.6 Additional Expansion**

HARTRON in consultation with Prison Department may procure additional equipment if required at any jail on pro-rate basis upto a maximum limit of 50% from the successful bidder without tendering.

\* \* \* \* \*

## **SECTION – 3**

# **TECHNICAL REQUIREMENT**

### 3. Technical Requirement

#### 3.1 General

The technical specifications specified in this section are the minimum suggestive specifications.

- i) Bids not meeting these minimum suggestive technical specifications are liable to be rejected. In case the equipment quoted exceeds/differ with the RFP technical specifications, the same should be clearly mentioned alongwith justification.
- ii) The bidder can indicate missing components if any, that may be considered necessary in his bid to implement and operate the facility to meet the required objectives of the project as has been laid down in this document.
- iii) The bidder will offer equipment that will best accommodate and meet the present and future requirements of Prison department.
- iv) The CCTV equipment shall be rugged in construction so as to keep dust, insect, termites & other foreign material out of the equipment.
- v) The System should provide inter-operability of hardware, OS, software, networking, printing, database connectivity, reporting, and communication protocols. System expansion should be possible through off-the-shelf available hardware
- vi) Surveillance CCTV system is required to ensure effective surveillance of an area as well as create a tamperproof record for post event analysis.
- vii) All CCTV cameras and related accessories should be from same OEM
- viii) The System shall provide as on - Line display of video images on LCD monitors located in Local control rooms.
- ix) System should facilitate viewing of live and recorded images and controlling of all cameras by the authorized users present in the LAN.

- x) The equipment supplied should tolerate Indian power and weather conditions. Further, all equipment shall comply with the applicable power and safety standards.
- xi) Bidder to specify required line voltage, voltage tolerance, frequency tolerance, max. Current consumption, max power consumption, maximum operating temperature, maximum operating humidity for each of the equipment.
- xii) One set of service and operation/instruction manual is required to be supplied with each of the equipment.
- xiii) Successful Bidder shall maintain necessary inventory of spares for smooth uninterrupted networking operations of these sites.
- xiv) The Successful Bidder shall provide patches, updates and upgrades of all the supplied software free of cost for five years.
- xv) All the equipments should be new and of the prevailing/current standard production of the manufacturer at the time of the proposal and shall not bid/ supply any equipment that is likely to be declared end of sale with one year of the date of the supply of the said equipment.
- xvi) The successful bidder is required to supply the latest version of software, providing all the features enumerated in this specification, at the time of award of contract. Equipment must be compatible with other Network vendor equipment. The principal vendor of products/equipment supplied under this project should have relevant quality certifications such as ISO 9001 and all the products should be certified by the original manufacturers.
- xvii) All the cables used in the networking shall be CAT-5E/6 and other electrical cable should be of BIS standards.

### 3.2 Suggestive CCTV layout Diagram

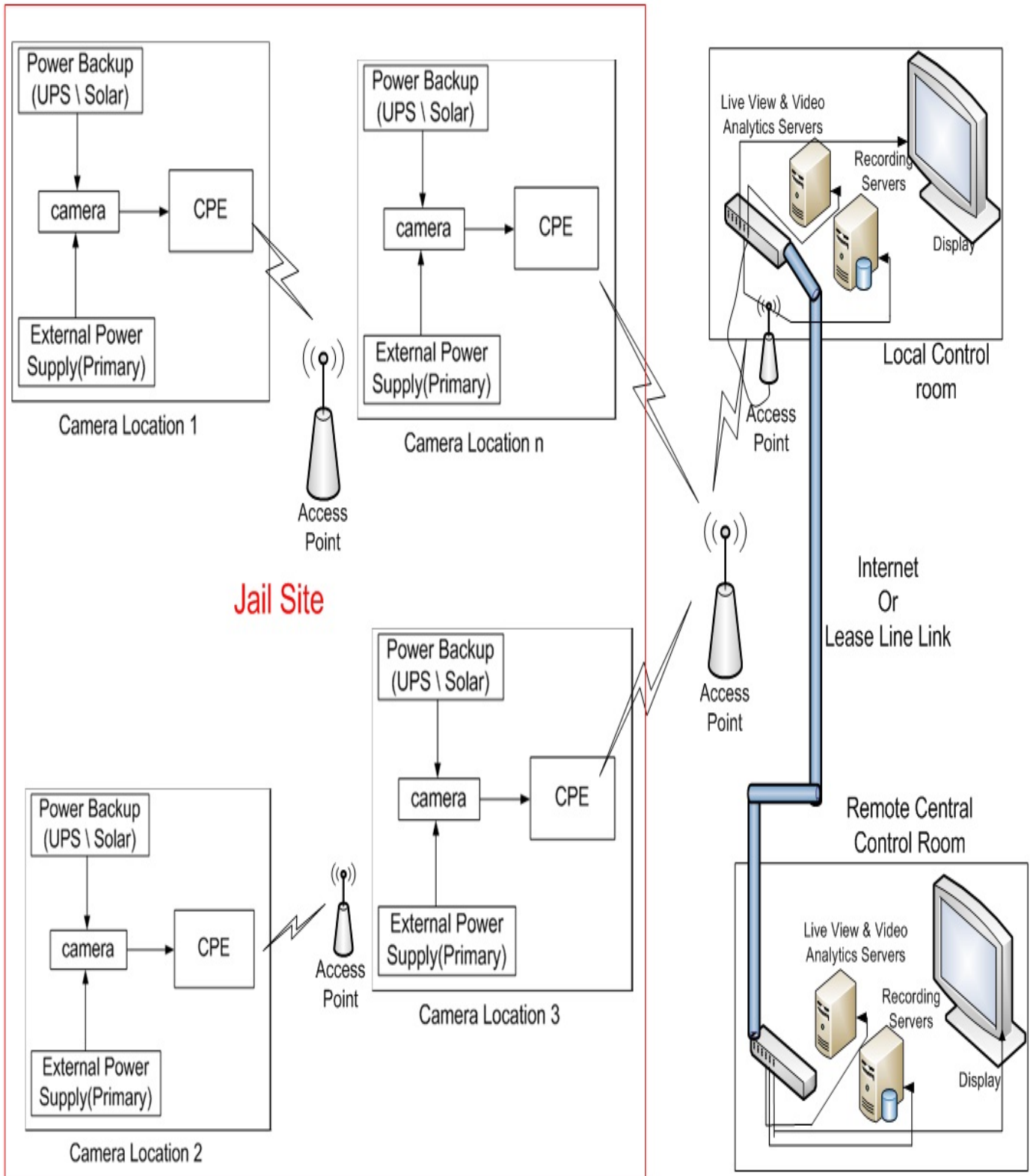

### **3.3 Bill of Material**

The suggestive Bill of Material is as under:-

#### **3.3.1.1 Fixed 2 Mega pixel High Definition Camera Specifications:**

##### **GENERAL**

The network (IP) camera shall be with 1/3-inch high resolution Mega pixel color camera, digital video

##### **Camera specifications**

- (i) The camera shall be a network (IP) based camera.
- (ii) The camera shall be available in NTSC and PAL formats.
- (iii) The camera shall offer dual stream upto a resolution of 2048 x 1536 in progressive scan format
- (iv) The camera as a minimum shall have a digital video resolution of 2048 x 1536
- (v) The imager type should be of CCD/CMOS.
- (vi) The camera shall digitize and compress the video using the latest in video compression technology and shall utilize a a minimum of H.264 video compression
- (vii) All the firmware/software upgrades shall be done remotely over the IP network.
- (viii) The camera should support IEEE 802.3af specifications for power over Ethernet.
- (ix) The camera shall provide the option to set each stream at variable bandwidths
- (x) The camera shall have an Ethernet (IP) interface using an RJ-45 CAT5, CAT5e or CAT6 UTP cable
- (xi) The camera shall as minimum provide the communication protocols such as TCP/IP, UDP/IP (Unicast, Multicast IGMP),

UPnP, DNS, DHCP, RTP, RTSP, NTP, IPv4, SNMP, QoS, HTTP, HTTPS, LDAP, SSH, SSL, STMP, FTP, MDNS

- (xii) The camera IP protocol shall communicate over the Ethernet network.
- (xiii) The camera should support Day / Night Operation. The minimum illumination in color should be 0.1 for day and 0.03 for night.
- (xiv) The camera should be fully password protected
- (xv) The camera should have a CS varifocal lens of 15-50 mm
- (xvi) The camera shall be comprise of a camera block “driver” which consist of a 1/3 or 1/4” CCD
- (xvii) The camera shall maintain operation at temperature of 32° - 122° F (0°-50° C) in normal operation
- (xviii) The camera should be fitted in a housing capable of withstanding conditions prevailing on an Indian port.
- (xix) Certifications: UL/CE, FCC/EN

#### **3.3.1.2 Pan Tilt Zoom (PTZ) Camera Specifications:**

##### **a) GENERAL**

The network (IP) PTZ Dome camera shall consist of a dome drive with a variable speed for pan and tilt with continuous 360° rotation, 1/4-inch high resolution color camera, motorized zoom lens with optical and digital zoom and auto focus and high resolution digital video of 4CIF (752x582 PAL) using the MPEG-4 compression algorithm and TCP/IP transmission.

##### **b) Camera specifications**

1. Network (IP) based camera available in NTSC and PAL formats.
2. maintain 30fps NTSC/ 25fps PAL video at 4CIF digital video resolution (704x480 NTSC/ 704x576 PAL)

3. The camera shall digitize and compress the video using the latest in video compression technology.
4. The camera shall have a minimum focal length of 3.5 mm to 129mm
5. The camera shall have a minimum Optical zoom of 37X and 12x digital
6. The digital video shall provide dual encoded video streams to allow simultaneous and independent viewing and recording of live video at different frame rates and/or quality.
  - a. The camera shall provide the option to set each stream at a frame rate between 1-30 NTSC /1-25 PAL
  - b. The camera shall provide the option to set each stream at variable bandwidth from 32 kbs to 12 Mbs
7. The camera shall have minimum built in 8 Input & 4 relay output
8. The camera shall have 1 photo coupled input & 1 Auxiliary Output
9. The camera shall have an Ethernet (IP) interface using an RJ-45 CAT5, CAT5e or CAT6 UTP cable
10. The camera shall as minimum provide the following communication protocols:TCP/IP, UDP/IP, RTP/IP, HTTP, IGMP, ARP ( HTTP, RTP/RTSP, Multicast, TCP/IP, ARP, ICMP, Telnet, FTP, PPPoE, SMTP, DHCP, NTP, uPNP, and etc).
11. The camera IP protocol shall communicate over the Ethernet network using Multicasting technology.
12. The camera shall comprise of Image sensor of a 1/3 or 1/4 CCD/CMOS
13. The camera shall deliver a 360° continuous pan travel
14. The camera tilt travel as minimum shall be between 0° to -90°

15. The camera shall provide 90 or more preset positions
16. The camera shall provide a freeze image option for preset call up
17. The camera should have a built in Electronic Image Stabilization.
18. The camera should have a built in Image Enhancement feature
19. The camera shall have a built in auto flip feature
20. The camera shall provide four (4) user defined patterns including pan, tilt, zoom, functions; pattern programming shall be available through the digital IP management system
21. The camera shall provide “home” settings for the camera to return after pre-programmed time frame
22. The camera shall provide privacy windows blanking.
23. The camera shall be a minimum high-resolution 550 TVL, B/W=680TVL
24. The camera shall have light sensitivity of 0.1 lux @ 50IRE, F1.2; 0.00007 lux @ 50IRE, F1.2 .
25. The camera shall provide angle of view of 55.5° wide and 1.6° tele.
26. The camera shall have white balance controls, manual or automatic
27. The camera shall have a minimum Electronic Shutter speed of (1/50 ~ 1/1,20,000 (27 Steps)
28. The camera shall have automatic backlight compensation (BLC)
29. The camera shall have automatic gain control (AGC).
30. The Video to Noise ration should be >50 dB
31. Camera shall provide Day/Night option – on/off

32. The cameras shall support Wide Dynamic Range
33. The camera shall maintain operation at temperature of 32° - 122° F (0°-50° C) in normal operation
34. The housing shall be mountable in Outdoor bracket mount
35. The camera shall meet the standards of NEMA 4X, IP 66

**The minimum certification should be UL/CE Listed, FCC**

**3.3.1.3 IP Video Management Software**

➤ **Live View Features**

- i) Support Live View of unlimited cameras (single server and multiple server)
- ii) Multiple Matrix view up to 8 x 8
- iii) Customizable Split Views
- iv) Following Function Button:
  - Camera Setting
  - Snapshot
  - Recording(Start/Stop)
  - Refresh
  - Full View
  - Audio
  - Volume
- v) PTZ Support:
  - Joystick with mouse
  - Pan
  - Tilt
  - Zoom
- vi) Digital Zoom on live view Screen
- vii) Camera Live view Tree which shows all the cameras :
  - Connected Cameras
  - Not Connected Cameras
- viii) Drag & Drop of any Camera to any matrix grid to start Video Streaming
- ix) Pre-Configured Centralize views by user. Default View option for any user
- x) Sequencing of Cameras
- xi) Sound Alarm for any configured event
- xii) Pop Up Alarm for any configured event

➤ **Recording**

- i) Triplex Mode – Live View, Recording and Playback simultaneously
- ii) Supported Encoding (H.264, MPEG4, MJPEG)
- iii) Recording at all resolutions and all frame rates
- iv) Option to record I chunks of 30 min, 1, 2, 4, 8 hours
- v) Continuous and Scheduled Recording

- vi) Scheduled Recording by using the day/time calendar
- vii) Switching of low frame rate (up to 1 fps) recording to normal frame rate in case of events or incident detection
- viii) Event based evidence export
- ix) Ability to record at settings different from live view
- x) Motion Detection and Video Analytics event based recording with pre-buffer and post-buffer option
- xi) Recording Analysis Screen:
  - Available Disk Space
  - Total Disk Space
  - Configurable Threshold Value
  - Automatic Deletion
  - Storage Calculator
  - Disk Administration
- xii) Configuration
  - Compression
  - Frame Rate
  - Resolution
  - Priority
  - Event Name
  - User Name/Client Name
- xiii) Snapshot of Recording
- xiv) Digital Zoom (with several zoom levels) for Post Recording Analysis
- **Playback**
  - i) Intelligent Search based on camera, date & time, Motion Detection events, Video Analytic events
  - ii) Sorting Recordings camera and start or end date & time
  - iii) Play, Forward and Seek options
  - iv) Slow and Fast playing
  - v) Export or Extract evidence
- **Centralize LAN/WAN streamer**
  - i) Centralize LAN/WAN streamer to forward one stream from camera to multiple users (either on LAN or WAN or both)
  - ii) Low Bit Streaming on WAN. Configurable low Bit Stream in software
  - iii) Mobile Streaming to view the video from a GPRS enabled phone
  - iv) Dual stream function to stream the video from same camera at two different resolutions (LAN/WAN)
  - v) Ability to stream at http and rtsp
  - vi) Ability to stream at different bit rates (same as camera, low, very low bit rate for mobile devices)
- **Camera Management**
  - i) Add/Delete Cameras using auto search function

- ii) Manual Addition/Deletion/Modification of Camera
- iii) Configure the camera properties
  - Live View
  - Recording
  - Video Analytics
  - General
- iv) Define Camera groups
- v) Different setting for Live View and Recording Video Streams
- **User Management:-**
  - i) User based camera or camera group access
  - ii) User Roles and levels
  - iii) Login & Authentication
  - iv) Add/Delete new users
- **Logs :-**
  - i) User Entered (configure & system actions)
  - ii) Recordings Import/Export
  - iii) Event Logs
    - Automatically
    - Manually
  - iv) Network Traffic
- **Recording Archival**
  - i) Magnetic Tape Media
  - ii) CD/DVD
  - iii) Network attached storage
- **Alarms**
  - i) Alarm Notification through E-MAIL, SMS, Physical Alarm
- **Alarms Generation Events**
  - i) Motion Detection based Alarms
  - ii) Recording Problem based Alarms
  - iii) Camera Disconnect( LAN) based Alarms
  - iv) Low Disk Space Alarms
  - v) Sound Notification on alarm event
  - vi) Video Pop Notification on alarm event
  - vii) Video Analytics (perimeter protection and intrusion detection based alarms)
  - viii) Camera tampering alarms
  - ix) Operator Alarm Notification Acknowledgement
  - x) Action on Alarm:
    - Recording
    - Snapshot
    - Inter Camera Trigger
    - Email
    - SMS
    - FTP
    - Camera Speaker
  - xi) Camera Mapping:

- Ability to start-stop recording of any camera based on events from other cameras
- Ability to move PTZ Cameras present based on events from other cameras

#### **3.3.1.4 Intelligent Video Analytics**

The Intelligent Surveillance System must provide integration to an Intelligent Video Analytics system. The Intelligent Video Analytics System shall be capable of detecting the following events:

➤ **People Events**

- i) Person entered restricted area
- ii) Person exited restricted area
- iii) Person loitering in restricted area
- iv) Person on fence line
- v) Person trespassing—tripwire

➤ **Counting Events**

- i) Person counted as entering
- ii) Person counted as exiting
- iii) Car entered lot
- iv) Car exited lot

➤ **Perimeter Protection based Video Analytic**

- i) For security at boundary against any unwanted activity.
- ii) External Boundary protection by virtual tripwire with alarm based system.
- iii) Sending Alerts in the form of Email and SMS to the security personnel.
- iv) Zoomed image of the Object Breached.
- v) Option to define multiple connected lines with maximum of 20 lines per shape.
- vi) Option to define warning zones with distance both inside and outside of Perimeter
- vii) Option to define direction as left-right, right-left, up-down, down-up, line-angle.

➤ **Intrusion detection**

- i) Analytic based on for locating of a moving Object in the restricted area.
- ii) Supporting multiple Intrusion Zone with single camera .
- iii) Specific Zone based Alarm System for various events .
- iv) Scheduled Automatic ON /OFF of the Video Analytic .
- v) Define any size Polygon as intrusion area.
- vi) Option to define direction and warning zones

➤ **Missing Object Detection**

- i) Define object of any size in the video
- ii) Option to define sensitivity. Time for which object is removed to raise alarm
- iii) These cameras will be installed in areas where moving objects will be present, thus camera should incorporate technology to reproduce clear images for both still and

moving objects within an image. The cameras should detect movement within the image and reproduces those areas with minimal blurring, while areas in the image with little or no movement should be displayed naturally with minimal jagged edges. clear images for both still and moving objects within an image. minimal jagged edges.

➤ **Abandoned Baggage Detection**

- i) Define Zones for monitoring left over or abandoned baggage detection.
- ii) Continuous Background extraction and matching for false alarm reduction.

**3.3.1.5 Wireless Access Point**

➤ **Wireless Access Point**

Outdoor Wireless Access Point for wireless communication with CPE connected to cameras

➤ **802.11n Outdoor Access Point**

- i) Outdoor Single Radio Access Point conforming to IEEE 802.11n with backward compatible with IEEE 802.11b/g
- ii) Data Rate up to 300 Mbps in 2 x 2 configuration
- iii) 2 x 2 MIMO technology for large coverage
- iv) Rugged IP67 Outdoor Enclosure
- v) Supports 802.11i and 802.1x Specification
- vi) Frequency Band – 2.400 – 2.497 GHz
  - 802.11b: Up to 11 Mbps
  - 802.11g: Up to 54 Mbps
  - 802.11n: up to 300 Mbps

➤ **Transmit Power**

Up to 24dBm

➤ **Security**

- i) 64-bit, 128-bit and 152-bit WEP encryption
- ii) 802.1X authentication
- iii) AES-CCM and TKIP encryption
- iv) WPA-PSK, WPA2-PSK, WPA-EAP, WPA2-EAP

➤ **Channel Bandwidth**

20/40MHz

➤ **Network Interface**

10/100 Mbps Ethernet Port Auto MDI/MDI-X Support

➤ **Management**

Web Interface over http

➤ **Power Supply**

24V, 48V PoE

➤ **Enclosure**

Outdoor Rugged IP67 Enclosure

➤ **Temperature**

0° – 55° Celsius

➤ **MSSID**

- Upto 8 SSID
- **AP Modes of Operation**  
AP, Repeater, Client, MSSID, MSSID with VLAN tagging

### 3.3.1.6 Power System for Each Camera Location and Access Point Location

Sr. No	Specification
6.1.1.	Power system should be self sufficient to run for 4 hrs even if all input power sources are not available
6.1.2.	There should be no single point of failure in power system
6.1.3.	Following input sources should be supported: <ul style="list-style-type: none"> <li>• AC (Utility Power)</li> <li>• UPS</li> </ul>
6.1.4.	All the equipment necessary including batteries to provide the uninterrupted supply and backup shall be provided by the bidder
6.1.5.	Power System should be such that it works under extreme outdoor temperature conditions (0° – 55°)
6.1.6.	UPS should be from reputed manufacturer
6.1.7.	Adequate capacity UPS or Power Controller used should prevent the battery from overcharge and deep-discharge
6.1.8.	Battery State and other Power parameters can be monitored using the maintenance terminal
6.1.9.	Overload Protection mechanism should be available in power system
6.1.10.	System health and any alarms should be available in form of light LED or Sound buzzer

6.1.11.	<b>Power System for Control Room</b>
6.1.12.	Power system should be self sufficient to run for 4 hrs even if all input power sources are not available
6.1.13.	There should be no single point of failure in power system
6.1.14.	Following input sources should be supported: <ul style="list-style-type: none"> <li>• AC (Utility Power)</li> </ul>
6.1.15.	Adequate capacity UPS backup of 4 hrs shall be available for all the control room equipments
6.1.16.	Overload Protection mechanism should be available in power system
6.1.17.	System health and any alarms should be available in form of light LED or Sound buzzer

### 3.3.1.7 Network

A Local Area Network (LAN) shall be provided for communication between the system elements. All interfaces to the LAN shall be a minimum of 1000BaseTX Ethernet and for servers 1000/10000BaseTX. The LAN may use additional technologies within the backbone for greater speed or distance. Acceptable types are:

### 3.3.1.8 Switches

Specification	Description
<b>Layer 2 Switch(24 Port)</b>	24 port Gigabit Ethernet Switch required in control centre LAN
	Supports Simple Network Management Protocol (SNMP)
	IEEE 802.1D bridging capability and loop detection
	IEEE 802.1Q tagged VLANs
	IEEE 802.1p traffic prioritization for multiple Quality of Service levels
	IEEE 802.1w rapid spanning tree with fast link support
	IGMP 1/2/3 snooping for IP Multicast support
	Multicast Network Traffic
	Link Aggregation
	Port Density: <ul style="list-style-type: none"> <li>▪ 1000 Base-FX and 10/100/1000 Base-T</li> <li>▪ Fiber Ethernet Media supports 1000 Base-FX single mode wavelength: 1310 nm / 1550nm. Connector: Standard SC</li> <li>▪ Copper Ethernet supports 10/100/1000 Base-T EIA/TIA 568 Cat3, 4, 5, 5e, 6 UTP/STP</li> <li>▪ 24 SFP based Gigabit Ethernet Ports and 2 SFP Gigabit Uplink for WAN connectivity</li> </ul>
	QOS: <ul style="list-style-type: none"> <li>▪ Policy based QOS features</li> <li>▪ 4 QOS queues per port</li> <li>▪ Multiple priority queues per port</li> <li>▪ Supports Ingress and egress bandwidth control</li> <li>▪ SP/WFQ/WRR packet scheduling</li> </ul>
	MAC Address Learning and Aging Notifications
	VLAN Trunking
	Loop Detection & Prevention
	Dynamic ARP Inspection

	DHCP Client Management
	Power: <ul style="list-style-type: none"> <li>▪ External Power Supply: Input: 48V DC/24V DC/230V AC</li> <li>▪ Two Power cards for redundant operation</li> </ul>
	Operating Temperature Range: 0° C – 50° C

### 3.3.1.9 UPS

Specification	Description
<b>Adequate capacity on-line UPS of reputed make. with four Hour Backup through SMF Batteries for monitoring and recording equipment and UPS for all the Control Room Equipments</b>	The <b>online</b> UPS shall have capability to provide 220V± 10 Volt at 50 Hz output with input voltage 180 –240 at 50Hz
	The UPS Battery shall be of reputed make
	UPS shall be able to give a backup of 4 hrs for all the control room equipments
	The UPS shall provide warning, 10 minute prior to shut down

Specification	Description
<b>Adequate capacity on-line UPS of reputed make. with one Hour Backup through SMF Batteries for cameras</b>	The <b>online</b> UPS shall have capability to provide 220V± 10 Volt at 50 Hz output with input voltage 180 –240 at 50Hz
	The UPS Battery shall be of reputed make
	UPS shall be able to give a backup of one hrs for each camera
	The UPS shall provide warning, 10 minute prior to shut down

### 3.3.1.10 Servers (Live view, Video Analytics & Recording), Storage & Monitors

Specification	Description
<b>Hardware for Network Video recorder of reputed make.</b>	The server provided shall come pre-loaded with Video Recording Software with DVD-Drive 52 X, PS/2 Mouse and keyboard.
	Intel Quad Core, 2.4 GHz, 8 MB Cache, DDR-2 667 MHz with, Internal Serial – ATA controller & ATA-100 EIDE-Controller or Equivalent or better system or better.
	HDD Interface IDE or better, RAM 4 GB or better,

	OS-Windows XP Home/XP Professional/Windows Server Free memory with 2 TB and shall be extendable up to 1.0 TB.
	Graphic Card: NVIDIA GeForce FX 5700 Ultra, FX 5900 Ultra or FX 5950 Ultra, Matrox Parhelia, ATI RADEOn 8500, 9500, 9800 or better
	Ethernet Card: Intel 10/100/1000 Mb/s Gigabit-Ethernet Network on board
	Sound Card: Internal AC-97 Audio-chip with Yamaha S-YXG50 Soft Synthesizer or better
	15.6" LCD Monitor
<b>Hardware for Live View &amp; Video Analytics of reputed make</b>	The server provided shall be able to provide high graphics display and shall come pre-loaded with Video Management System for Live View and Video Analytics for Analytics Software with DVD-Drive 52 X, PS/2 Mouse and keyboard.
	Intel Quad Core (Single/Multiple) 2.4 GHz, 8 MB Cache, DDR-2 667 MHz with, Internal Serial — ATA controller & ATA-100 EIDE-Controller or Equivalent or better system or <b>better</b> .
	HDD Interface IDE or better, RAM 4 GB or better, OS-Windows XP Home/XP Professional/Windows Server Free memory with 2 TB and shall be extendable up to 1.0 TB.
	Graphic Card: NVIDIA GeForce FX 5700 Ultra, FX 5900 Ultra or FX 5950 Ultra, Matrox Parhelia, ATI RADEOn 8500, 9500, 9800 or better
	Ethernet Card: Intel 10/100/1000 Mb/s Gigabit-Ethernet Network on board
	Sound Card: Internal AC-97 Audio-chip with Yamaha S-YXG50 Soft Synthesizer or better
<b>Hardware for Video Management Configuration Client of reputed make.</b>	The PC provided shall be able to provide high graphics display and shall come preloaded with Video Management System Software with DVD-Drive 52 X, PS/2 mouse and keyboard.
	Intel Core-2 Duo, 2.4 GHz, 2 MB L2 Cache, with 1066 MHz FSB, 8 X AGP Port, Internal Serial — ATA Controller & ATA-100 EIDE-Controller or Equivalent or better system.
	500 GB 7200 rpm Serial-ATA HDD or better, RAM 4 GB DDR-2 667 MHz expandable to 8 GB, OS-

	Windows XP/Windows 7.
	Ethernet Card: Intel 10/100/1000 mb/s Gigabit-Ethernet Network on board.
	15" LCD Monitor
<b>Hardware for Storage of Reputed Make.</b>	Storage should be in RAID 5,1 or 10
	NAS, DAS or SAN
	Storage should be Scalable
	HDD will be SATA,SAS or batter
	146GB,300GB,500GB,1TB or batter Drive
	Connectivity Ethernet ,SCSI or Fiber,
<b>32" LCD Monitor for Live View Display of Video.</b>	Integrated 32" <b>LCD</b> or better, Aspect Ration: Widescreen 16:9
	Display : <b>LCD</b> Active Matrix TFT
	Resolution: 1080p or better
	Brightness : 400 cd/m2 or better, Contrast Ration: 500: 1 or better
	Viewing Angles 150H/150V Degrees or better

- The quantity of the equipments will be decided by the vendor & may vary according to the hardware used by him.
- The quantity for cables and conduit will be calculated by the bidder as required.
- The specifications mentioned above are only suggestive. Hartron reserves the right to modify these specifications and such changes shall be informed to the prospective bidders by uploading the same on Hartron web site.

## **Section 4**

### **Eligibility criteria for Bidders**

#### **4. Eligibility Criteria**

**The Bidder:** Bidder should have the capability to implement projects in terms of geographical spread, industry experience, requisite manpower of required qualification and experience, project management skills and quality/level of work. Bidder should have a proven record in implementing heterogeneous system integration projects including Networking & System Integration projects. The bidder should have reasonable long-standing relationship with active and passive component manufacturer, which they are proposing and these should have been deployed by the bidder in such IP based Networks elsewhere.

##### **4.1 Bidders general qualification**

- (i) This RFP is open to all firms/companies both from within and outside India, who are eligible to do business in India under relevant Indian laws as in force at the time of bidding.
- (ii) Firm/company declared by GoH to be ineligible to participate for corrupt, fraudulent or any other unethical business practices shall not be eligible during the period for which such ineligibility is declared.
- (iii) Breach of general or specific instructions for bidding, general and special conditions of contract with GoH may attract a proceeding to declare a firm/company ineligible for a certain period or certain number of consecutive tender calls.

##### **4.2 Minimum eligibility criteria**

- (i) The bidder may comprise a single company or consortium. In case of the consortium, an agreement among the consortium partner for the specific project clearly defining the role and responsibility of each of the consortium partner as well as the lead bidder out of the consortium partner to be enclosed with the pre-qualification bid.
- (ii) The bidding firm/company/consortium partners must be registered under the Companies Act 1956.
- (iii) The bidding firm/company/consortium partners must be having valid ISO 9001 certification at the time of bidding.

- (iv) The bidding company/consortium partners must in the business of providing System Integration/IP CCTV solution providers/networking companies for the last three years
- (v) The Turn over of the lead bidder must be minimum Rs.20 crores (Rs. Twenty Crores) in the last financial year i.e. 2009-10 with a consolidated Turn over of Rs. 50 Crores (Rs. Fifty crores) for the last three years 2007-08, 2008-09 and 2009-10 from networking/system integration/surveillance and related business. This must be bidding company's turn over and not that of any group of companies. A copy of last three financial years relevant Balance Sheets should be submitted with the offer.
- (vi) The lead bidder should have made profits as per the audited balance sheets in the last three financial years and should be in sound financial position as judged by the Evaluation Committee for this purpose.
- (vii) The bidder/s should have at least 2 years of proven experience of providing Project /facility Management of System Integration.
- (viii) The bidders or their technology partners must have successfully implemented IP CCTV projects as given under, in the last three years either in India or abroad of consolidated minimum value of Rs 5 crores. The satisfactory reports from the said customers including copies such purchase orders including technical as well as commercial aspects are to be enclosed with the Pre-Qualification.

1. One IP CCTV project of 25 nos. of Nodes

2. Two CCTV projects of 10 Nodes each.

The agreement with the technology partner whose experience is reflected in the bid has to be enclosed in the prequalification bid.

- (ix) The bidder/s should have at least 20 nos. of qualified manpower on the rolls for integration of such projects related services.
- (x) The bidder/s must be authorized to bid on behalf of the manufacturer and should submit an upto date valid authorization letter till the currency of the contract from original manufacturers for such

equipment and its accessories, which are not manufactured by them and supplied under this RFP.

- (xi) The Original Equipment Manufacturers (OEM) of the critical equipments like fibre equipment, camera hardware, servers, software cabling etc should have ISO international quality certification for manufacturing these products. The Bidder/s shall attach the copy of the OEM's ISO Certificate along with the bid.
- (xii) The bidder/s must have signed an agreement with OEM for such equipment and its accessories for providing the technical support including spares for the period of contract i.e. five years after the completion of the final acceptance test. The copy of such agreement(s) to be attached with pre qualification bid.
- (xiii) The bidder/s should have support centers in Haryana/Chandigarh/Delhi or in case bidder/s does not have support center in Haryana/Chandigarh/Delhi, bidder/s should set up the support centers within a month in case the contract is awarded to it and the same should be functional till the period of performance warranty/support and project Management of the sites to be connected which ever is later. The bidder will submit an undertaking in this regard along with the Bid.
- (xiv) The bidder/s must certify that the Technology quoted is State of the art and latest.
- (xv) The design/solution provided by the bidder/s for the project must be in accordance to the industry best practices.

**Documentary evidence in support of all the above mentioned eligibility criteria should be furnished with pre qualification bid.**

**Important Note:** Hartron reserves the right to amend any/all the above eligibility criteria depending upon the out come of the pre-bid conference to ensure fair play and competition in the

bid process. Any such changes will be notified in writing to all those who have purchased this document.

\* \* \* \* \*

## **Section-5**

# **Bidding Process & Procedure of Submission of Bids**

## **5. Bidding Process**

### **5.1 Advice to the bidders**

Bidders are advised to study this RFP document carefully before participating. It shall be deemed that submission of Bid by the bidder/s have been done after their careful study and examination of the RFP document with full understanding to its implications. Any clarifications/resolutions of the doubts must be sought at or before the pre-bid conference.

### **5.2 Sale of bid document**

(i) A complete set of this RFP document can be purchased from Haryana State Electronics Development Corporation, S.C.O. 111-113, Sector 17-B, Chandigarh – 160017 by the bidders in person against a non-refundable amount of Rs. 5000/- through Demand Draft/Bankers Pay Order from a scheduled bank, drawn in favour of “Managing Director, HARTRON”, payable at Chandigarh - or -

The complete set of this RFP document can be downloaded from our website [www.hartron.org](http://www.hartron.org). However, such bidders downloading the document from the site are required to send an email to [hartron.project@gmail.com](mailto:hartron.project@gmail.com) for records. Also such bidders are required to deposit the non refundable RFP cost of Rs 5000/- in the form of draft drawn/bankers pay order from a scheduled bank in favour of “MD Hartron” payable at Chandigarh along with the bid.

(ii) Bids not submitted in prescribed form will be rejected.

(iii) RFP document will be sold from 9.00 am to 5.00 pm on all working days starting from 23.11.10 till 22.12.10.

### **5.3 Validity of the bid**

The bid should be valid for 180 days from the opening of the Commercial bid OR 8 Months from the last date of submission of bid, whichever is later.

### **5.4 Transferability of the RFP document**

This RFP document is non-transferable.

### **5.5 Misplacement of the RFP document**

HARTRON shall not be responsible for any postal delay about non-receipt /

non-delivery of the documents.

**5.6 Pre bid discussions, place, time and date:**

Haryana State Electronics Development Corporation Limited,  
S.C.O. 111-113, Sector 17B,  
Chandigarh – 160017.  
At 11.30 am on 09.12.10

**5.7 Address at which the bids are to be submitted:**

Haryana State Electronics Development Corporation Limited,  
S.C.O. 111-113, Sector 17B,  
Chandigarh – 160017  
Phone - (0172) – 2704922, 2710743, 2706105 Fax - 2705529

**5.8 Last time and date for receipt of bid :**

Upto 2.30 pm on 23.12.10

**5.9 Place, time and date of opening of pre-qualification bid:**

Haryana State Electronics Development Corporation Limited,  
S.C.O. 111-113, Sector 17B,  
Chandigarh – 160017  
At 3.30 on 23.12.10

**5.10 Earnest money deposit (EMD)**

All bids must be accompanied by an earnest money of Rs. 5,00,000/- (Rs. Five Lacs only) in the form of Demand draft from a scheduled bank in India and shall be valid for at least six months, in favour of 'HARTRON' payable at Chandigarh. No interest shall be paid on the earnest money under any circumstances. Bids without earnest money shall be summarily rejected.

**5.11 Pre-bid conference**

- (i) A pre-bid conference (PBC) shall be held as per clause no.5.6. In this PBC, tenderer would address the clarifications sought by the bidders with regard to the RFP document and the project. The bidders would be required to submit their queries to the tenderer in writing at least 5 (five) days prior to the PBC. Queries not submitted within this deadline may not be taken up at the PBC.
- (ii) Bidders that having purchased the **RFP document till the date of PBC shall only be allowed attend the PBC**, even if they do not have any specific queries. These bidders would be required to register

for the PBC at HARTRON. No clarifications to any query after the PBC shall be entertained.

- (iii) Tenderer will entertain queries of and clarifications sought by only those companies who have purchased this RFP document.
- (iv) Tenderer reserves the right not to respond to any/all queries raised or clarifications sought if, in their opinion and at their sole discretion, they consider that it would be inappropriate to do so or do not find any merit in it. The minutes of the PBC shall be circulated by tenderer to all those companies who have purchased this RFP document. Nothing in clause no. 5.11 above shall be taken or read as compelling or requiring tenderer to respond to any question or to provide any clarification. No extension to any deadline referred to in this document will be granted on the basis or grounds that tenderer should respond to any queries to provide any clarification.

#### **5.12 Procedure for Submission of the Bid**

Sealed offers prepared in accordance with the procedures enumerated below should be submitted to HARTRON, Chandigarh on or before the last date and time 18.11.10 upto 2:30 p.m. The bidder/s should submit their bids in three parts i.e. Pre-qualification Bid, Technical Bid and Commercial Bid. All bids sealed individually should be kept in a separate sealed cover super scribed with separate titles as specified below:-

- a) "Pre-qualification Bid for CCTV surveillance for Haryana Prisons."
- b) "Technical Bid for CCTV surveillance for Haryana Prisons."
- c) "Commercial Bid for CCTV surveillance for Haryana Prisons"
- d) The bidders should submit **one copy** each of Pre-qualification, and technical bid. The bidder shall submit **two copies** of commercial bids, with the title mentioned as "Original commercial bid and Copy of the commercial bid". The each bid should be in properly bound form **with all pages numbered**. The language of the bid and all documents related to the bid must be written in English language. If any document is in language other than English, then the bidder/s is required to

- enclose a self attested translated English version of such documents.
- e) The bidder/s shall also submit the soft copy of Pre-qualification, technical and commercial bids on separate CDs/pen drive in Microsoft Word or pdf format duly packed in the respective envelopes.
  - f) All the documents viz. Pre-qualification Bid, Technical Bid and Commercial Bid prepared as above are to be kept in a single sealed cover super scribed with RFP Number, Due Date, Item and the wording “Do not Open Before 1530 hrs on 23.12.10”
  - g) **Late bids:** The cover should also indicate the name and address of the bidder/s to enable the bid to be returned unopened in case it is declared “Late” by the evaluation committee.
  - h) No bid will be considered unless and until each page of the bid document is duly signed by the authorized signatory.
  - i) Prices should not be indicated in the Pre-qualification or Technical Bid.
  - j) All the columns of the quotation form (Proforma 11 to 12) shall be duly, properly and exhaustively filled in. The rates and units shall not be overwritten. Rates shall be both in the figures and words.
  - k) It is mandatory for all bidders to quote F.O.R. destination prices inclusive of all taxes i.e. excise duty, freight, sales tax, octroi, insurance, customs, service tax, etc. Any change in excise duty, custom duty and service tax or any other levies/taxes announced by the Government of India during the currency of the contract, then the same shall be applicable on presentation of the proof during currency of the contract. No change in other duties including sales tax, custom duty effect due to devaluation of rupees shall be entertained.
  - l) Price Bids determined to be substantially responsive will be checked by the evaluation committee for any errors. If there is a discrepancy between the quoted rate in figures and the quoted rate in words, the rate in words will take precedence. Arithmetic errors will be rectified on the following basis. If there is a discrepancy between the unit rate and the total cost that is obtained by multiplying the unit rate and quantity, the unit rate multiplied by quantity shall prevail and the total cost will be

corrected unless in the opinion of the evaluation committee there is an obvious misplacement of the decimal point in the unit rate, in which case the total cost as quoted will govern and the unit rate corrected. If there is a discrepancy between the total bid amount and the sum of various costs, the sum of the various costs shall prevail and the total bid amount will be corrected.

- m) The amount stated in the Form of Financial Bid will be adjusted by the evaluation committee in accordance with the above-mentioned point for the correction of errors and, shall be considered as binding upon the bidder/s. If the bidder does not accept the corrected amount of bid, its bid will be rejected, and the EMD shall be forfeited.
- n) Any omission in filling the columns of "units" and "rate" or pertaining to the Taxes/levies, service tax as applicable etc., shall deemed to be treated as inclusive in the total project cost.
- o) All corrections must be duly signed by the Bidder.

#### **5.13 Documents comprising the bids**

The bids prepared by the bidders according to the procedure mentioned at clause no. 5.12 should comprise of the following:-

##### **5.13.1 Original bid proposal shall consist of the following:**

- (i) Sealed envelope containing the draft of Earnest Money as mentioned at clause no. 5.10.
- (ii) The RFP document in original duly signed by the authorized signatory on each page acknowledging the terms of RFP.
- (iii) Sealed envelope containing the Pre-qualification Bid.
- (iv) Sealed envelope containing the Technical Bid.
- (v) Sealed envelope containing the Commercial Bid.

##### **5.13.2 copy of Commercial bid proposal shall consist of the following:**

- (i) Sealed envelope containing the copy of the Commercial Bid.

##### **5.13.3 Pre-qualification bid shall consist of following :-**

- (i) Bid proposal sheet duly filled in, signed and complete in all respects. (Proforma – 1).

- (ii) Particulars of the Bidder as per Proforma-2.
- (iii) Copy of audited balance sheets for the last three financial years.
- (iv) Copy of the valid ISO certificate of the bidder as well as OEMs.
- (v) List of 20 engineers on its roll at the time of bidding.
- (vi) Undertaking for the project management of the project (Proforma – 4).
- (vii) Undertaking with regard to the compliance of warranty for all the equipment and accessories as per the clause no.6.10.
- (viii) Undertaking to provide Warranty certificates of each and every equipment and its accessories effective from the date of successful completion and acceptance of final acceptance test as specified at clause no.6.16 and the period of warranty should be as per the clause no 6.10.
- (ix) Attested photocopies of documents to establish eligibility in terms of each eligibility criteria as mentioned at Section-4 of this document.
- (x) Attested Photo copies of completion certificate and award of order of all the projects handled, along-with the contact details of the clients, which includes Name of concern, address, name of contact person, designation, phone number(s), fax, mobile number, e-mail address(s), etc.
- (xi) An affidavit from the original equipment manufacturer (OEM) with regard to the authorization for items like active components, passive components, etc. that the bidder is representing them, and that the bidder's commitment shall be met in totality by them. In case the the bidder is other than the manufacturer, an agreement between them and the OEMs shall also required to enclosed along with the proposal for all acyive and passive components.
- (xii) Copy of the agreement signed between the bidder and the original manufacturer for providing the technical support during the implementation, commissioning and project management

period for such components and their accessories supplied under the project.

- (xiii) Bidder shall provide an undertaking for providing the warranty certification of all active and passive components for 5 years and 20 years respectively as the case may be from the manufacturer of the equipment.
- (xiv) Complete details such as address, contact person/phone, fax, e-mail of branch offices as well as support centers in Haryana/Chandigarh/Delhi along with proof of after sale service facilities at these centers, in case such facilities are not available, then an undertaking to this effect as specified in clause no.(xiii) of 4.2 of this document.
- (xv) Manufacturers warranty as per Proforma 3.
- (xvi) Indemnification from proprietary & patent rights Proforma 7 & 8.

#### **5.13.4 Technical bid shall consist of following**

- (i) The bidder has to give comprehensive plan detailing project schedule, team structure, implementation methodology, training details, project and management of the project, etc. in technical bid and shall give an undertaking that the proposed network to be installed and commission shall be complete in all respect adhering to the requirements of this RFP. (Proforma 5)
- (ii) The bidders are required to submit with their offers, detailed technical literature of the systems offered to enable a clear understanding of various technical aspects.
- (iii) Bidder shall specify the brand name, make and technical specification of all the equipment and accessories quoted for this project for each jail (Proforma 9).
- (iv) An undertaking from the bidder to ensure the compliance with existing Govt. of India policies/regulations applicable to the such network/connectivity. (Proforma 5).
- (v) Plans for User Training as per clause no.2.4 of this document.

- (vi) Acceptance test plans
- (vii) An undertaking that after the expiry of the project management period, the bidder will handover the total system in running condition in accordance to the clause no.6.18, (Proforma 4).
- (viii) An undertaking from the bidder that he shall accordingly train the manpower of respective departments of Haryana Govt. as per the clause no. 2.4 of this document.
- (ix) Technical Deviation Proforma 10.

**5.13.5 Commercial bid shall consist of the following**

- (i) Bid prices duly filled, signed and complete as per the price schedule on the prescribed quotation form (Proforma 11 to 13).
- (ii) The bidder can quote, separately, for any other item, which the bidder may think is essential or may be required while executing the project, which is not included in the Section-3.
- (iii) Bidders shall quote year-wise annual maintenance contract (AMC) charges for Two years with spares for taking up maintenance of all such equipments supplied under this project after the expiry of project management period/warranty period (Proforma-12 and 13).

**5.14 Opening of bids and Procedure of evaluation**

- (i) An evaluation committee will evaluate the bids on Quality cum Cost Based Selection (QCBS) methodology i.e. the aggregate scores of the technical bid (70%weightage) and Commercial bids (30% weightage) will be made. The Bids upon opening will be initially examined to determine whether they are complete, whether any computational errors have been made, and whether the bids are generally in order.
- (ii) The bidder shall designate minimum one person to represent the bidder in its dealing with tenderer in relation to the proposal submitted by the bidder. Tenderer will assume that the person(s) designated is authorized to perform all tasks, including, but not limited to, providing information and responding to enquiries on behalf of the company.

- (iii) Only Pre-qualification bid shall be opened on the day of opening of the bids at 3.30 p.m. on 18.11.10 (see clause no.5.9) in the presence of bidders' representatives. The bidders' representatives who are present shall sign a register evidencing their attendance.
- (iv) Technical bid will be opened for those bidders whose bids shall meet all the prequalification criteria unconditionally as specified in clause no.5.13.3. The Place, date and time of the opening of the technical bid shall be notified separately.
- (v) Technical bid document shall be evaluated as per the following steps:
- a. **Preliminary Examination of Technical Bids:** The technical bids will be examined to determine whether they are complete, whether the documents have been properly signed and whether the bids are generally in order. Any bids found to be non-responsive for any reason or not meeting the minimum levels of the performance or other criteria specified in the various sections of this RFP will be rejected and not included for further consideration.
- b. **Evaluation of Technical Bids:**  
The selection of the bidders shall be based on **Quality cum Cost Based Selection (QCBS) methodology** i.e. the aggregate scores of the prequalification and technical bid (70%weightage) and Commercial bids (30% weightage) will be made. The said Bidder(s) will be required to further enter into contract with Haryana Prison. The threshold score for technical qualification would be 70 out of marks 100 based on the evaluation method given below.

Evaluation Criteria				
Sr No	Description	Criteria	Marks	Total Marks
1	<b>Experience Of the Firm:</b> The bidding firm/company or their consortium/technology (OEM) partner must have successfully implemented CCTV surveillance projects as under in the last three years either in India or abroad.			
i)	Implementation of Project covering surveillance of jails, campus, city/office complex etc. with minimum 25 nodes.	>3 2-3 1	15 10 7	15

ii)	Implementation of wireless Projects covering surveillance of jails campus, city/office complex etc with minimum 20 nodes	>3 projects 2-3 1	15 10 7	15
2	Implementation of any WAN project with minimum 50 nodes on fibre/lease line/wireless in the last 3 years	>3 projects 2-3 1	20 15 7	20
3	<b>Technical presentation</b> of the entire solution including backbone connectivity and/or wireless connectivity, IP surveillance, control room, video analytics as offered for jails etc.		30	30
	<b>Field demonstration</b> of the solution by the bidder		20	20
	<b>Total</b>			<b>100</b>

The threshold score for technical qualification would be 70  
Hartron reserves the right to amend any/all the above evaluation criteria depending upon the out come of the pre-bid conference to ensure fair play and competition in the bid process. Any such changes will be notified in writing to all those who have purchased this document.

**c. Financial bids evaluation:**

- i. Bid Currency -Prices shall be quoted entirely in Indian Rupees only.
- ii. Financial bids of those Bidders will be opened who obtain minimum qualifying Technical scores.
- iii. The Total Cost of project quoted by Bidders will be considered for calculation of financial marks.
- iv. The commercial scores will be calculated as
  - **Financial Marks = (Minimum Financial Quote / Financial Quote) x 100**
  - Where
    - Financial Marks = Normalized financial marks of the bidder under consideration
    - Financial Quote = Evaluated cost for the bidder under consideration
    - Minimum Financial Quote = Minimum evaluated cost for any bidder
- v. **Correction of Errors:**
  - Financial Bids shall be checked by the Hartron and Prison Department for any arithmetic errors. During the evaluation of the Financial bids, errors will be corrected by the Hartron in consultation with Prison Department as follows:

- Where there is a discrepancy between the amounts in figures and in words, the amount in words will govern; and / or
- Where there is a discrepancy between the unit rate and the line item total resulting from multiplying the unit rate by the quantity, the minimum amount as quoted will govern.
- The amount stated in the Financial Bid will be adjusted by the Hartron in consultation with Prison Department in accordance with the above procedure for the correction of errors and shall be considered as binding upon the Bidder. If the Bidder does not accept the corrected amount of Financial Bid, its Tender will be rejected and EMD of the Bidder will be forfeited and the Bidder will be liable for other appropriate action as decided by Hartron in consultation with Prison Department.

**d. Final Evaluation of Bids:**

- **Final Evaluation** - The overall score will be calculated as follows:-
- **Final Scores** = (0.7 x Technical Marks) + (0.3 x Financial Marks)
- Where
  - Final Scores = Overall evaluated marks (score) of Bidder under consideration
  - Technical Marks = Technical marks(score) for the Bidder under consideration
  - Financial Marks = Normalized financial marks (score) of the Bidder under consideration
- (vi) The tenderer may conduct clarification meetings with each or any Bidder to discuss any matters, technical or otherwise.

Any effort by the bidder to influence the tenderer in the process of evaluation of technical Bids, bid comparison or the tenderer's decisions on acceptance or rejection of bids may result in rejection of the bidder's bid.
- (vii) The bidders will also be required to make a detailed presentation covering various aspects on technical parameters defined in this RFP for the said sites to be connected, services supports, maintainability, implementation schedule, upgradability and its integration with existing SWAN .

- (viii) The tenderer may also ask the bidders to arrange visits of officers to the network sites already established and claimed in the bid.
- (ix) Further, the scope of the evaluation committee also covers taking of any decision with regard to this RFP, execution/ implementation of the project including management period.
- (x) No further discussion/interface will be held with the bidder whose bid has been technically disqualified/rejected.
- (xi) Bidder shall perform all the obligations specified in accordance with the terms and conditions laid down in this RFP. Though formats for Technical bid and Commercial bids are given separately, bidder shall add his remarks and comments under “any other relevant matter. Notwithstanding the fact that the RFP is descriptive, if the bidder feels that the RFP is deficient in anyway in defining scope of supply, scope of services etc for successful implementation and facility management of the project for five years, bidder should include the same under “any other” with explanation in Technical Bid and price under relevant head in commercial bid, if there is any price implication for the inclusion, found essential for successful project implementation. Thus, Proposals received will be considered as an offer to satisfy the requirements of tenderer as described in this Request for Proposal and bidder shall be obligated to implement the project as per scope of work finalized by tenderer.
- (xii) All details provided by the Bidder should be specific to the requirements specified in this RFP. Detailed clarification may be provided by Bidder, if so desired by tenderer. The Bidder shall specify the responsibilities of tenderer, if any, other than already mentioned in the RFP, separately for the successful implementation of the project.

#### **5.15 Criteria for rejection of bids**

The bid(s) may be rejected if any one or more of the following conditions are not fulfilled:-

- (i) Bids not made in compliance with the procedure mentioned at clause no. 5.12.

- (ii) Failure on part of the bidder to provide appropriate information as required in the bid proposal or any additional information as requested by the tenderer, including any supporting document.
- (iii) Incomplete or conditional bids - bids that do not fulfill all or any of the conditions as specified in this RFP.
- (iv) Bids without earnest money deposit (refer Clause no.5.10).
- (v) If found to have a record of poor performance such as abandoning works, not properly completing the contract, inordinately delaying completion, being involved in litigation or financial failures, etc.
- (vi) Failed to provide clarifications related thereto, when sought.
- (vii) Applicants who are found to canvass, influence or attempt to influence in any manner the qualification or selection process, including without limitation, by offering bribes or other illegal gratification, shall be disqualified from the process at any stage.
- (viii) Validity of the bid not as per the clause No. 5.3 shall be considered as non-responsive and would be disqualified.
- (ix) The submission of more than one bid under different names by one bidder - If same is found at any stage, all the bids by that bidder will be rejected.
- (x) Material inconsistencies in the information submitted.
- (xi) Misrepresentations in the bid proposal or any supporting documentation.
- (xii) Bid proposal received after the last date and time specified at clause no.5.8.
- (xiii) Bids found in unsealed cover, unsigned bids, bids signed by unauthorized person and unsigned corrections in the bids.
- (xiv) The bid shall contain no erasures or overwriting except as necessary to correct errors made by the bidder, in which case such corrections shall be authenticated by the person or persons signing the bid.
- (xv) All pages of the bid must be signed and sequentially numbered by the bidder.

(xvi) The decision of evaluation committee in this regard shall be final and binding on the bidders.

(xvii) Bids not submitted on the prescribed Proformas enclosed with this RFP.

#### **5.16 Acceptance of the bid**

(i) The valid bids received will be evaluated by the tenderer to ascertain the best, technical superior, commercially optimal bid in the interest of Haryana Prison.

(ii) Tenderer do not bind itself to accept the lowest or any bid and reserves the right to:

- a) reject any or all bids with/without any reason;
- b) accept/prefer any bid without assigning any reason.

(iii) Tenderer reserves the right to appoint any consultant or consultants to help tenderer for evaluation of the bid.

#### **5.17 Cross checking**

Tenderer reserves the right to contact and verify bidder's information, references and data submitted in the bid proposal without further reference to the bidder.

#### **5.18 Absence of specifications**

The absence of specifications details regarding any equipment to be supplied under this RFP implies that best general practices will prevail and that first quality material and workmanship will be applied as per the discretion of tenderer. Certification standards, when available, for the to-be-installed equipments and materials, will prevail.

#### **5.19 Cost involved in tendering**

The Bidder shall bear all costs associated with the preparation and submission of its bid, including the cost of presentation for the purposes of clarification of the bid, if so desired by the tenderer. The tenderer will in no case be responsible or liable for those costs.

#### **5.20 Amendment in the RFP document**

The amendments in any of the terms and conditions including technical specifications of this RFP document will be notified in writing either through

post or by fax or by email to all prospective bidders who have purchased the RFP document and will be binding on them.

#### **5.21 Withdrawal of bid proposal**

No bid proposal will be withdrawn subsequent to the deadline for the submission of bids. However, the bidder is allowed to modify or withdraw its submitted bid any time prior to the last date & time prescribed for submission of the bids, by giving a written intimation to the Tenderer.

#### **5.22 Right to negotiate**

- a. The Hartron and Prison Department jointly or the evaluation committee reserves the right for negotiation with the bidders.
- b. The negotiation shall be carried out with the bidder having scored highest as per the Quality cum Cost Based Selection (QCBS) methodology laid in the clause no 5.14 by the HARTRON and Prison Department Jointly / any other competent authority / Special high power purchase committee of the Haryana Govt. as per the procedures/policy of the Haryana Govt. from time to time.
- c. The tenderer also reserves the right to chose part or whole of the technically acceptably bids at individual costs quoted in the commercial bids.

#### **5.23 Contract agreement**

A contract agreement will be signed between the successful bidder and Prison Department directly.

#### **5.24 Earnest money refund**

- (i) The draft of earnest money to the bidder(s), who fail(s) to qualify for the technical bid, will be returned back by tenderer to the authorized representative of the bidder against a proper receipt or will be sent by the registered post at the mailing address of the bidder as specified in the bid within four weeks of opening of the pre-qualification bid.
- (ii) The draft of earnest money to the bidder(s), who fail(s) to qualify for the commercial bid, will be returned back by tenderer to the authorized representative of the bidder against a proper receipt or will be sent by the registered post at the mailing address of the bidder as

specified in the bid within eight weeks after completion of technical bid evaluation.

- (iii) The draft of earnest money to the bidder(s), who qualify(s) for the commercial bid, but do not get the order for the project will be returned back by tenderer to the authorized representative of the bidder against a proper receipt or will be sent by the registered post at the mailing address of the bidder as specified in the bid within one month after signing of contract agreement between tenderer and the successful bidder.

#### **5.25 Letter of intent and Performance Bank Guarantee**

- (i) After Acceptance of a Bid Proposal as mentioned at clause no. 5.22 of Section 5, a letter of intent will be issued by the tenderer to the successful Bidder.
- (ii) **Acceptance of the letter of intent:** The successful bidder shall accept the Letter of Intent within 7 (seven) days from the date of issue of the Letter of Intent by returning a duly signed copy to tenderer.
- (iii) **Signing of contract :** The successful Bidder shall enter into the Contract Agreement with Prison Department within 10 (Ten) days of the acceptance of the Letter of Intent.
- (iv) **Performance bank guarantee:** While signing the Contract Agreement with Haryana Prison, the successful bidder within 15 (fifteen) days of signing the Contract agreement shall furnish unconditional irrevocable Performance Bank Guarantee of 10% of the total value of the project cost from a Nationalized Bank in favour of "Managing Director, HARTRON" on the prescribed Format (as mentioned at Annexure 3), which will be renewed every year by the bidder till the currency of the contract. The said bank Guarantee shall be renewed by the bidder 30 days before the expiry date. However, the last renewal shall be for the period of one year and six months. The said Performance Bank Guarantee be extendable by the HARTRON as per the requirement and shall be kept in full force and effect for the

full term of the Contract Agreement including the project management period. Further, the decision of the tenderer with regard to the Performance Bank Guarantee shall be binding on the successful bidder. The tenderer may forfeit the Performance Bank Guarantee for any failure on part of successful bidder to complete its obligations under the Agreement. The Performance Guarantee shall be denominated in Indian Rupees and shall be in the form of a Bank Guarantee issued by a scheduled bank located in India.

- (v) **Award of Contract:** Tenderer shall formally award contract on the successful bidder upon the receipt of the Performance Bank Guarantee as mentioned at (iv) above.

#### **5.26 Right to vary quantities**

Though the bidders shall submit their bid for turnkey implementation of the project, tenderer reserves the right to include only a part or whole or none (in the event of not getting a viable solution within the budget estimated) of the above as scope of the successful bidder. Tenderer shall also reserves the right vary the qty. of the equipment during the bidding process or at the time of award of contract. The tenderer also reserve the right to split up the total scope among two or more bidders who agree to meet such a scope, if found beneficial in the long run for Haryana Prison. Hence the bid be prepared carefully considering the scope of each item individually and computing the total.

#### **5.27 Right to accept any bid and to reject any or all bids**

The tenderer reserves the right to accept any bid, and to annul the tender process and reject all or any bids at any time without assigning reason prior to award of Contract, without thereby incurring any liability to the affected bidder or bidders or any obligation to inform the affected bidder or bidders of the grounds for the tenderer's action.

#### **5.28 Changes in technical specifications and price bid**

- (i) Tenderer reserves the right to effect changes in the Technical Specifications after the pre bid discussions with the bidders. Any such

change will be notified in writing to all those who have purchased this document.

- (ii) Once quoted, the bidder shall not make any subsequent price changes, whether resulting or arising out of any technical/ commercial clarifications sought regarding the bid, even if any deviation or exclusion may be specifically stated in the bid. It is expected that all clarifications are sought for earlier and the bid requirements understood clearly by the bidder before submitting the bid. Such price changes shall render the bid liable for rejection. However, the Tenderer reserves the right to request the bidder/s to give revised commercial offer after technical evaluation, if the situation so warrants.

**5.29 Proprietary rights**

The bidder/supplier shall indemnify the tenderer against all third party claims of infringement of patent, copyright, trademark and trade designs arising from use of the goods or any part thereof in India.

**5.30 Patent rights**

The Bidder shall indemnify the tenderer against all third-party claims of infringement of patent, trademark or industrial design and intellectual property rights arising from the use of the Goods or any part thereof.

**5.31 Additional information/clarification**

Tenderer reserves the right to ask for any additional information, as it may deem necessary to evaluate the bid proposal. Bidders that fail to submit additional information or clarification as sought by evaluation committee within 10 days of the receipt of tenderer's letter requesting for such additional information and/or clarification, their bids will be evaluated based on the information furnished along with the bid proposal.

\* \* \* \* \*

## **SECTION – 6**

### **TERMS and CONDITIONS OF CONTRACT**

## **6. Terms & Conditions of Contract**

### **6.1 Use of RFP document and other Information**

- (i) Successful bidder shall not, without the tenderer's prior written consent, disclose the contract agreement, or any provision thereof, or any specification, pattern, sample or information furnished by or on behalf of tenderer in connection to any person other than a person employed by the tenderer in the performance of the contract agreement and the scope of work. Disclosure of document/information to any such employed person shall be made in confidence and shall extend only so far as may be necessary for such performance.
- (ii) Successful bidder shall not, without the tenderer's prior written consent make use of any document or any information specified in (i) above, except for the purpose of performing the contract agreement and the scope of work.
- (iii) Any document other than this contract agreement shall remain the property of the tenderer.

### **6.2 Change in the minimum specified work**

- (i) Tenderer may at any time by written intimation to the successful bidder, make changes in the minimum specified work.
- (ii) The successful bidder shall not perform changes in the minimum specified work, until tenderer gives permission for such change in writing on the basis of estimate provided by the successful bidder.
- (iii) Mutually agreed change in the minimum specified work shall constitute as a part of the contract agreement and all the provisions and contract agreement shall apply on the said change.
- (iv) Any change in the minimum specified work that may be required for the successful implementation of the project and not involving any significant additional costs shall be carried out by the successful Bidder at no additional cost or expense to the tenderer.
- (v) In the event of withdrawal or discontinuance of any item or items and consequent ceasing of or reduction in demand the successful

bidder shall not be entitled to any compensation. Tenderer will, however, make all reasonable endeavors to give warning of any impending complete withdrawal or of any reduction seriously affecting quantities likely to be required under contract.

- (vi) If during the currency of the contract, the specifications of any item or items to be supplied become obsolete, the successful bidder shall continue to comply with demands for the supply of the said item or items in accordance with the new specifications at rate not higher than already agreed rates at the time of contract, and the successful bidder will not be entitled for any compensation also.

### 6.3 Changes in contract agreement

Except the changes as mentioned in clause 6.2 above, no modification of the terms and conditions of the Contract Agreement shall be made except by written amendments signed by the both successful bidder and Haryana Prison.

### 6.4 Project Milestones

- (i) The final acceptance of sites to be connected must be completed within six months from the date of award of contract.
- (ii) The milestones of the project are mentioned below:-

Sr.No.	Milestone	To be achieved
1	Supply, delivery at site, installation & commissioning Integration of the all the Jails	With in 5 month from the date of award of contract
2	Training of officials	With in 5 months from the date of award of contract
3	First Acceptance test	With in 5.5 months from the date of award of contract
4	Final Acceptance test	Within 6 months from the date of award of contract

- (iii) If the successful bidder fails to deliver services prescribed at clause 6.4 above the same shall be subject to 0.5% penalty per week of

the contract value subject to a maximum of 10% of the total value of the project.

- (iv) The above penalty, if any, shall be recovered from the payments to be made to the successful bidder under this project or recovery will be made from amount of Earnest Money or Bank Guarantee submitted by the successful bidder to tenderer provided that:
- No recovery of penalty will be made, if tenderer accepts the delays by extending the milestones upto two week by recording in writing that the exceptional circumstances were beyond the control of the successful bidder and there was no loss to Haryana Prison.
  - Where the delay on the part of successful bidder is more than 2 weeks subject to maximum of 4 weeks, the matter of extension of Time frame for accomplishing the particular delayed activity will be referred to the Committee appointed by tenderer with related documents that there are genuine reasons for delay on the part of successful bidder and that no loss will result to Haryana Prison in case extension is allowed. In case the time frame for the activity as mentioned in the milestones above is extended, no penalty during the extended period shall be recovered from the successful bidder.
- (v) The unexcused delay in performing of any services as mentioned in the milestones by the successful bidder in the prescribed period may render him liable to any or all of the following penalties:-
- The penalty as mentioned at clause no. 6.4 (iii) above.
  - Forfeiture of earnest money and revoking of Security (Performance Bank Guarantee).
  - Termination of the contract as default.

#### **6.5 Responsibilities of Successful bidder**

- (i) The successful bidder is responsible to execute all but not limited to the work specified under scope of work as specified in section-2 of this RFP.

- (ii) The successful bidder shall maintain the network infrastructure located at various sites as mentioned in this RFP, for the implementation and operation of the project and allied services.
- (iii) The successful bidder shall handle all the technical and implementation matters.
- (iv) Responsibility of Electricity earthing and its testing according to the norms at each location while installation of equipments is of successful bidder. If at any location the earthing is not working properly or there is no-earthing, then the successful bidder will arrange/repair the same. If any equipment starts malfunctioning due to improper earthing during the currency of the contract, the same equipment will be replaced/repared by the successful bidder at his own cost and the successful bidder will not be compensated for the same.
- (v) To lay down the whole cabling upto each point and the power cabling upto and from the electric supply source, near to each equipment supplied by the successful bidder under this RFP is the responsibility of the successful bidder.
- (vi) Inputs/guidelines for the preparation of site as per standard norms shall be submitted by the successful bidder after site.
- (vii) Civil works, if any, required for passive-cabling systems will be the responsibility of the successful bidder.

#### **6.6 Responsibilities of Tenderer**

- (i) To provide requisite space at each jail for installation of cameras and other equipments as well as for local control room.
- (ii) To provide the adequate electricity power at each jail
- (iii) To provide appropriate environmental conditions, necessary power facilities for the system, access to the premises, a secure equipment storage area, and suitable conditions for the successful bidder's officials.

## **6.7 Price fall**

- (i) The prices charged for the Items/services supplied under the contract by the successful bidder shall in no event exceed the lowest price at which the successful bidder sells the goods or offers to sell Items of identical description to any persons/organizations including the tenderer, Department of the Central or State Government or any Statutory undertaking of the central or State Government, as the case may be, till the signing of the contract.
- (ii) If, at any time during the said period the successful bidder reduces the sale price, sells, or offers to sell such goods to any person/organization including tenderer or any Department of State or Central Government or any statutory Undertaking of the Central or State Government as the case may be, at a price lower than the price chargeable under the contract, the successful bidder shall forthwith notify such reduction, or sale or offer to sell to the tenderer and the price payable under the contract for the supply of material after the date of coming into force of such reduction or sale or offer to sell shall stand correspondingly reduced.

## **6.8 Inspection/tests of the items/equipments**

- (i) Inspection committee so constituted shall have the power to inspect the items before, during or after installation and to reject the same or any part or portion, if he or they be not satisfied that the same is not at par or according to the specifications submitted by the successful bidder. The hardware equipment i.e server, if required can be put to the operational as well as burning test for a minimum period of 72 hours.
- (ii) The successful bidder shall not be paid for supplies rejected as specified at (i) above.
- (iii) Successful bidder shall neither claim nor be entitled to payment for any damage that rejected supplies may suffer from any harm whatsoever incidental to a full and proper examination and test of such supplies.

- (iv) Tenderer shall be under no liability whatsoever for rejected items and the same will be at the successful bidder's risk.
- (v) Rejected supplies shall be removed by the successful bidder at his own expense within 10 days after notice has been issued to him of such rejection, and failing such removal of rejected goods will be at successful bidder's risk.
- (vi) Super inspection of already inspected may be carried out at the discretion of the tenderer after installation, by such officer or team of officers as may be authorized by tenderer. The provisions of conditions mentioned at (i) to (v) above will also apply to the Super Inspection.

#### **6.9 Site visit**

- (i) The cost of the site visit in the Haryana city will be borne by bidder himself; tenderer is not liable to provide any facility to the bidder(s) for such visits.
- (ii) Tenderer on its own discretion can cancel such permissions at any moment without any notice to the bidder(s).

#### **6.10 Warranty**

- (i) Successful bidder will also be responsible for providing comprehensive on site warranty of all active and passive components for 5 years and 20 years respectively as the case may be from the manufacturer of the equipment supplied under this RFP.
- (ii) Warranty shall be deemed to commence from the date of the successful completion and acceptance of the final acceptance test conducted by the technical committee constituted by Hartron and Haryana Prison.
- (iii) During the warranty period, it will be the responsibility of the successful bidder to rectify any defect and update the System and the software by incorporating necessary patches, upgrades and updates as and when released by the original supplier or found

necessary by tenderer so as to ensure that the Solution is functioning to provide the best performance.

- (iv) Successful bidder shall make available to tenderer the necessary manpower at all times to incorporate changes either in the reports or statements and changes in the business rules for the supplied modules. It is also his responsibility to install the software changes to all systems.
- (v) Successful bidder shall undertake the preventive maintenance of all supplied equipments including active and passive components supplied under this RFP once in every quarter during the currency of contract so as to ensure the smooth functioning of the system and he will have to strictly adhere to this Schedule.

#### **6.11 Facility Management and Service Level Agreement**

- (i) The systems supplied shall be considered as operational when all the sites of Haryana city under this RFP are working, providing all/specified services in full capacity at all locations in this outdoor surveillance system. The service(s) at a site is considered as available, when that service(s) in full capacity can be used from all the service positions at that particular site.
- (ii) During this period of facility management, the successful bidder will attend/rectify the defects at all sites within 24 hours from the time/date, complaints are reported to the successful bidder or its representatives. In case the reported problem is not resolved within 24 hours at such locations, a fine of Rs.1000/- per day per site shall be charged. If the successful bidder does not attend/rectify the defect/problem, HARTRON at its own discretion will have the right to arrange repairs/replacement at the cost and risk of the successful bidder and in such case at the end of the warranty period, the warranty will be extended for duration equivalent to the total time during which the system remains out of order.
- (iii) The scope of project management include, but not limited to:
  - System administration

- Maintaining and managing the active networking equipment including the passives like racks, cabling, patch panel
  - Supporting the provision of last mile access.
  - Managing and maintaining the electrical system and utilities
  - Sufficient spares to be kept for the smooth and uninterrupted operation of network as per the defined SLAs.
  - Interacting with the bandwidth providers for the sustained connectivity for the backbone network.
  - Interacting with the leased line and Internet Service Providers for the continuous availability of the facilities.
- (iv) Bidder is required to mention the skill level (i.e. certified Hardware/Software Engineers having minimum qualification of B.E./B.Tech with relevant experience. Tenderer reserves the right to verify the technical credential of the manpower to be deputed by the bidder.
- (v) During the period of facility Management, the successful bidder should ensure uptime of the entire system of at least 99% (average for the quarter). If the uptime is found less than 99%, then the amount equivalent to the  $((100 - \text{Uptime}\%) * 3)\%$  of the Project Management amount for that quarter will be deducted from the total amount of facility Management as penalty. The reports for the uptime should be generated weekly. If the average of this weekly uptime is found less than 95% for any four (4) consecutive week's period, then HARTRON on behalf of and in consultation with Haryana Prison after getting the advice of Haryana Prison can take the penal action against vendor including but not limited to the revoking of the Performance Bank Guarantee. The report of each week should reach the Client by the end of the next week, otherwise the uptime of that week will be treated as zero. During the period of AMC to be awarded by the Haryana Prison or the agency so authorized after the successful completion of the warranty period, as specified in section 6.10 of this document, the

penalty as specified above for not maintaining the required up time as mentioned above will also be applicable.

For example: - Suppose the uptime for a particular quarter is 96%, then  $((100-96)*3)=12\%$  of the Project Management amount for that quarter will be deducted as penalty from the total amount of the Project Management.

- (vi) Downtime will exclude outages due to the following:
- a) The Bidder, if faced with problems in timely delivery of services, which have dependencies on the Service Provider (s) or any other source(s), which are beyond their control at any time, shall immediately inform the tenderer in writing, about the causes of the delay and tentative duration of such delay etc. The tenderer, on receipt of such notice, shall analyze the facts at the earliest and may at its sole discretion, relax the penalties accordingly.
  - b) Outages caused by reasons beyond the scope of work of the successful bidder
  - c) Time taken for scheduled maintenance/troubleshooting either for preventive purposes or improvement in function or other purposes provided however that such periods do not exceed 60 minutes in a quarter.
  - d) Time taken for reconfiguration or other planned downtime situations provided however that such outages taken along with those created by item b above do not exceed 60 minutes in a quarter;
  - e) Scheduled shutdowns as required by tenderer
  - f) Force Majeure events

SLA and penalty clauses as mentioned above have been detailed herein in order to have uniform understanding by the bidders so that commercial offers received shall be uniform comparison. However, the Tenderer reserves the right to alter the SLA or the Penalty conditions thereof after the finalisation of the successful

bidder after re-assessing the need, real cost of SLA in various Slabs, SLAs achievable/required as per the applications etc. The Tenderer also reserves the right to modify the SLA and penalty conditions thereof reasonably, as guided by the foregoing principles, during the tenure of the project as per application requirements.

#### **6.12 Third Party Agency**

A third party agency if required may be involved by the tenderer for the inspection, installation, auditing & monitoring the Wireless CCTV Surveillance System for Haryana Prisons to be installed under this RFP. The successful bidder shall cooperate with this third party agency and shall allow to use monitoring tools.

#### **6.13 Spares**

The successful bidder will ensure that supplies of necessary maintenance equipment and spare parts including active and passive components be made available for the life of the machines or at least for contract duration on continuing basis. For active components especially routers, their OEM should have their spares depot in India and should be able to deliver the spares, the next business day. However, it has no bearing on the uptime and related clauses/sections as specified in this RFP.

#### **6.14 Dispatch Documents**

- (i) With every dispatch of goods or materials under the contract, the successful bidder will prepare Delivery Challan in triplicate. The original delivery challan is to be sent by the successful bidder to the tenderer.
- (ii) The second copy of Delivery Challan to be returned to the successful bidder by the respective designated officers at each site with the quantities or numbers received duly noted and signed thereon. The said duly signed Delivery Challan received by the

successful bidder from the respective intending officers shall also be forwarded to tenderer for further necessary action.

- (iii) The third copy to be sent by the successful bidder to the user for record in its office.
- (iv) The successful bidder shall raise the invoice in the name of Director General of Prison, Haryana and the said duly verified bills alongwith duly verified challans by the officials of Haryana Prison to Hartron for the release of the payment.

#### **6.15 Condition of items supplied**

- (i) This is subject to the condition that the materials are securely packed by the successful bidder in sound containers and the consignment is accepted by the carriers without any adverse remarks as to the packing or the condition of the containers. In case of any adverse remarks, the responsibility for the losses in transit will rest with the successful bidder.
- (ii) The successful bidder will not be entitled to charge or be paid for supplies broken, lost or damaged in transit. Such supplies shall be removed by the successful bidder at his own expense. The decision in this regard taken by tenderer shall be binding and final.

#### **6.16 Acceptance tests**

Acceptance Test shall be conducted in two steps:

A Testing Committee of the officials from HARTRON, Prison Department, Head of the respective site or any officer or person as constituted and duly authorized by the Client will perform Acceptance Tests for Hardware at each site as the case may be. In any case, if the quality and the quantity of the items supplied by the vendor at one or all the locations are found unacceptable, the vendor shall be held responsible for covering up the loss in terms of both quantity as well as quality wise. All the hardware related payments to the vendor as per the payment schedule mentioned at Section 6.17 would be made after the successful clearance of the following acceptance tests.

##### **i) 1<sup>st</sup> Acceptance test**

- (a) The first acceptance test shall involve successful supply, delivery at site, installation & commissioning of all the sites.
- (b) The Brand, Model No., Specifications and quantity of all the supplied and installed hardware items must match with respect to the list and particulars of the items to be supplied for that unit.
- (c) All the required software must be installed and working properly.
- (d) The successful bidder can be asked to demonstrate all the features/facilities mentioned in the bid and product brochures attached along with the bid.
- (e) All of the equipments, which are to be installed at that unit, must be installed and communicating with control room with a 95 % uptime and 4 ranges for a period of 15 days. The successful bidder is required to provide the log files to prove their claim of 95% uptime for the said period.

**ii) Final Acceptance test**

- (a) All the required hardware equipments must be installed at each of the jails, and should be working properly as per the 1<sup>st</sup> Acceptance Test for a period of another 15 days with an up time of 99% for the entire system. The successful bidder is required to provide documentary evidence in terms of log files to claim having achieved the 99% uptime.
- (b) The installed surveillance system must demonstrate its capability of providing the services enumerated in the contract. Successful bidder will arrange the test equipment if required for performance verification. Successful bidder will also provide documented test results.
- (c) All of the required system software must be installed and implemented properly and should go through all of the required testing.
- (d) All of the sites must be communicating properly as per the requirement mentioned at Section-3.

- (e) Training part of the project should be completed.
  - (f) On the successful completion of the acceptance test and after HARTRON and client are satisfied with the working of the system, the acceptance certificate signed by the authorised representative of HARTRON, authorised representative of Haryana Prison and successful bidder will be issued by the HARTRON on behalf of and in consultation with Haryana Prison to the successful bidder. The date on which such certificate is issued shall be deemed date of the successful commissioning of the system.
  - (g) Any delay by the successful bidder in the performance of its contracted obligations shall render the successful bidder liable to the imposition of appropriate liquidated damages, unless agreed otherwise by HARTRON and Haryana Prison.
- iii) In the event the successful bidder is not able to complete the installation to link all the sites on outdoor surveillance as defined by tenderer due to non availability of sites by Haryana Prison or any other reason beyond the control of the successful bidder, tenderer and Haryana Prison, the successful bidder and Tenderer may mutually agree to redefine the milestones so that successful bidder can complete installation and conduct the Acceptance Tests within the redefined milestones for such sites..

#### **6.17 Payment schedule**

##### **BOOT**

- (i) No payment will be made in advance for any supplies/services under this project.
- (ii) The successful bidder shall be paid on quarterly basis at end of each quarter for those jails which have been accepted in the final acceptance test at the rates finalized. Each jail shall be treated as separate entity for the purpose of release of quarterly Payment after deduction of downtime penalty if any.

- (iii) The cost mentioned in the quarterly release of payment would be used for additional requirement in future during the period of contract.
- (iv) The increase in technical requirements (with respect to no. of ports, telephone instruments, features, number of cables etc.) to the extent of 10% (to cater for change in number of co-located offices & remote offices) with respect to the maximum requirement as per the technical and operational requirements given in the Agreement shall be covered by the operator in the same cost. In case of increase of more than 10%, the cost as verified by the committee including third party agency for providing the same shall be added in Quarterly Release of Payment.
- (v) The successful bidder's request for payment shall be made at the end of each quarter by invoices along with following supporting documents.
  - Jail wise Performance statistics
  - Log of Down time calculation and Uptime percentage.
  - Any other document necessary in support of the service performance acceptable to tenderer.
- (i) On receipt of such invoice after verification by the indenting department i.e Prison department and after deducting Income Tax, other taxes and any Penalties, tenderer shall pay the amount within a period of 30 days.
- (ii) **Other payments:-** 50% payment for training will be released after its completion and the remaining 50% after completion of the BOOT period.
- (iii) **Earnest money** of the vendor will be released after the clearance of Final Acceptance Test of the project.

- (iv) **Bank Guarantee** will be released after the completion of five years and six months of the signing of the contract agreement or the BOOT period whichever is later.
- (v) **Any other payment**, which is left to cover in the payment schedules, mentioned above, will be made after the three months of the clearance of Final Acceptance Test of the project.

#### **6.18 Handing Over:**

- (i) The infrastructure at all the jails shall be handed over to the tenderer after the 60 months (to be calculated from the date of issue of final acceptance certificate).
- (ii) The successful bidder shall hand over the complete facilities at all the jails including equipment/ infrastructure in good running condition and supported by all reports, documents, updates/upgrades record pertaining to softwares for all the equipment supplied and installed under this project, project management, configuration management, etc. The successful bidder shall also provide complete inventory record of all the equipment including necessary tools installed and operational alongwith their maintenance record at the time of transfer of the project.
- (iii) The successful bidder shall comply with all other requirements as may be prescribed under Applicable Laws to complete the divestment and assignment of all the rights, title and interest of the successful bidder in the RFP free from all Encumbrances absolutely and free of any charge or tax to Haryana Prison or its nominee.
- (iv) The liabilities of the successful bidder for the said project shall not be transferred to the tenderer or Prison Department and the

successful bidder shall be fully responsible for any litigation arising out of it at any time before or after the transfer.

- (v) Subject to the fulfillment of the above mentioned conditions, the project shall be transferred to the tenderer upon a payment of Rupee One by the tenderer to the successful bidder. The successful bidder shall pay all transfer cost and stamp duty as applicable on the transfer of the project

#### **6.19 Sub-contracting of the project**

In the event successful bidder intends to use Sub-contractor for any part of the Project, the following shall be adhered to:

- (i) The sub-contracting of the entire project shall not be allowed. Further, the successful bidder will be solely responsible for the whole project and all of the conditions of the project, even if he sub-contracts any part of the project to any other party. In other words sub-contracting would not absolve the successful bidder from the responsibility for the complete project and its conditions. However, sub-contracting of Project Management Services, system integration would not be allowed under this RFP and shall be the sole responsibility of the successful bidder.
- (ii) The successful bidder may subcontract a part of project after informing the tenderer for the same. However, the successful bidder will be solely responsible for the implementation of any part of the project sub contracted to the satisfaction of tenderer.
- (iii) Evidence that all obligations imposed by the RFP on the Bidder have been fully understood and accepted where applicable by the Sub-contractors.

#### **6.20 Change in company structure**

The Membership/Board structure of the bidder, if changed after the bidder is selected, the successful bidder shall accordingly inform the tenderer of such changes.

### **6.21 Compliance with laws, permits**

The successful bidder shall comply with all local, state rules, regulations, ordinances, codes, and laws relating to the work or the conduct thereof and shall secure and pay for any permits and licenses necessary for the execution of the work and successful bidder shall be responsible for the same.

### **6.22 Liability insurance**

Successful bidder shall agree to maintain General Liability Insurance, Worker's Compensation, and tenderer Liability Insurance to cover all its personnel engaged in the performance of the services herein described, as well as damages arising as a result of the performance of such services. Successful bidder further agrees to require his subcontractor(s), if any, to maintain General Liability Insurance, Worker's Compensation, and Tenderer Liability Insurance. The successful bidder shall also be responsible for Employees Provident Fund (EPF) and other worker compensation issues, if any, applicable on his or his subcontractors' personnel.

### **6.23 Forfeiture of earnest money**

- (i) If the bidder withdraws his bid before the expiry of validity or after the acceptance of the bid, the earnest money deposited by the successful bidder will be forfeited.
- (ii) If the successful bidder fails to comply with any of the terms, conditions or requirement of this contract and the technical specifications for the equipment requirement as indicated in various sections of the RFP document, the earnest money deposited by the bidder will be forfeited.
- (iii) In case successful bidder fails to comply with the project milestones as specified at clause no.6.4, the earnest money deposit will be forfeited.
- (iv) In case of issue of the Letter of Intent, (Refer Clause no. 5.25) if the bidder fails to:

- (a) accept the Letter of Intent by returning a duly signed copy within the time limit specified; and / or
- (b) execute the contract agreement; and / or
- (c) furnish the performance bank guarantee as specified in this Document.

The earnest money deposit will be forfeited

#### **6.24 Force Majeure**

Neither party shall be responsible to the other for any delay or failure in performance of its obligations due to any occurrence commonly known as Force Majeure which is beyond the control of any of the parties, including, but not limited to, fire, flood, explosion, acts of God or any Governmental body, public disorder, riots, embargoes, or strikes, acts of military authority, epidemics, strikes, lockouts or other labour disputes, insurrections, civil commotion, war, enemy actions. If a Force Majeure arises, the Bidder shall promptly notify Tenderer in writing of such condition and the cause thereof. Unless otherwise directed by Tenderer, the successful bidder shall continue to perform his obligations under the contract as far as is reasonably practical, and shall seek all reasonable alternative means for performance not prevented by the Force Majeure event. The successful bidder shall be excused from performance of his obligations in whole or part as long as such causes, circumstances or events shall continue to prevent or delay such performance.

#### **6.25 Termination of the contract**

- (i) In the event of the bidder failing duly and properly to fulfill the contract or committing breach of any of the terms and conditions of this contract or repeatedly supplying goods liable to rejection hereunder or failing, declining, neglecting or delay to comply with any demand or requisition or otherwise not executing the same in accordance with terms of this contract or not achieving the milestones mentioned at clause no 6.4 or if the bidder or his agent or servants being guilty of fraud in respect of this contract or any of his partners or representatives found directing, giving, promising

or offering any bribes, gratuity, gift loan, perquisite, reward or advantage pecuniary or otherwise to any person in the employment of Government in any way relating to such officers or person or persons, officer or employment or if the bidder or any of his partners become insolvent or apply for relief as insolvent debtor or commence any insolvency proceedings or make any composition with his/their creditors or attempts to do so, then without prejudice to tenderer rights and remedies otherwise, tenderer shall be entitled to terminate this contract forth with and may claim back all or part of the money already paid to the bidder.

- (ii) The termination of this contract in whole or part under any conditions shall not be affected by the acceptance, meanwhile or subsequently, of supplies accepted or made at any station whether in ignorance of the termination or otherwise.
- (iii) If during the currency of the contract, the successful bidder becomes bankrupt or otherwise insolvent or is likely to become insolvent or bankrupt, tenderer may, at any time, terminate the contract agreement by giving written notice to the successful bidder. Notwithstanding the above, such termination will not prejudice or affect any right of action or remedy which has accrued or will accrue thereafter to tenderer.
- (iv) Further the tenderer shall also have the unfettered right to repudiate and rescind the Contract if there is any breach of the Contract by the Successful Bidder including but not limited to the occurrence of any of the following events or contingencies:
  - a) Minimum balance not maintained vide revolving guarantee.
  - b) Default achieving milestones affecting the overall time schedule
  - c) Quality of the network/servers/infrastructure facility/ software etc. not as per specifications/agreements.

#### **6.26 Consequences of termination**

- (i) Upon termination, the successful bidder shall deliver or cause to be delivered all works carried out for and on account of the State

Govt. and all data and records required from or on account of the State Govt.

- (ii) Termination of the contract agreement shall not affect any continuing obligations of the successful bidder under the contract agreement, which, either expressly or by necessary implication, are to survive its expiry or termination such as confidentiality obligations of the successful bidder.
- (iii) Upon termination of the contract agreement for any reason whatsoever, the successful bidder shall return to the tenderer, any and all confidential information and any other property of the tenderer.
- (iv) Tenderer may procure services similar to those undelivered, upon such terms and in such manner, as it deems appropriate, at the risk and responsibility of the successful bidder and the successful bidder shall be liable for any additional costs for such services.
- (v) The successful bidder shall continue the performance of the contract agreement to the extent not terminated.
- (vi) Upon termination of the contract agreement for whatsoever, tenderer shall have the right to impose the following penalties:-
  - (a) Forfeiture of earnest money
  - (b) Revoking of performance bank guarantee by tenderer on advice of State Govt.
  - (c) Imposition of appropriate penalties.

#### **6.27 Insurance of items**

Successful bidder shall insure all the delivered items till acceptance and during the Project management period of two years from the date of issuance of acceptance certificate.

- (i) The successful bidder shall arrange for comprehensive Insurance of equipment and works covering transit, storage, erection, commissioning and maintenance as may be necessary and for all such amounts to protect the interest of the Tenderer against all risks. The scope of such Insurance shall cover the entire value of

the equipment and Infrastructure being supplied for the entire Contract period.

- (ii) The Transit cover shall be on all risks for inland transit.
- (iii) The successful bidder shall arrange workmen compensation insurance, which shall be at the cost and responsibility of the successful bidder.
- (iv) Any loss or damage to the components during handling, transporting, storage and erection, till such time the complete setup is taken over by the Tenderer, shall be to the account of the successful bidder.
- (v) All costs on account of insurance liability and necessary premium will be on successful bidder's account and such Insurance charges shall be indicated as a fixed Lumpsum as in the Commercial Bid. .
- (vi) Any no-claim bonus shall be to the account of the tenderer.

Tenderer on behalf of Haryana Prison, shall be the principal holder of the policy. Tenderer reserves the exclusive right to assign the Policy

#### **6.28 Arbitration**

- (i) In the event of any dispute or difference arising between the Successful Bidder and tenderer out of or in connection with the Contract or RFP or any of the terms and conditions contained therein or as to the interpretation or any other matter, both the parties shall resolve such dispute or difference first by mutual discussions. If any dispute or difference still persists, it shall be referred to Home Secretary to Govt. Haryana for Arbitration to be conducted in accordance with Arbitration and Conciliation Act 1996. The arbitration will be held in Chandigarh and the proceedings shall be conducted in English. The parties to the dispute will instruct the Arbitrator(s) to render a decision within 30 days of the date of their appointment and such a decision shall be binding on both the parties.

- (ii) This RFP and the Contract shall, in all respects, be governed by and construed in all respects in accordance with the laws of the Republic of India.
- (iii) In relation to any legal action or proceedings to enforce the Contract, the parties to the Contract irrevocably submit to the exclusive jurisdiction of the courts in Chandigarh to the exclusion of any other court or courts that may otherwise have had such jurisdiction and waive any objection to such proceedings on grounds of venue or on the grounds that the proceedings have been brought in an inconvenient forum.

**6.29 Acquaintance with all conditions**

The bidder acknowledges that he has made himself fully acquainted with all the conditions and circumstances under which the supplies required under the contract will have to be made or furnished and with all the terms, clauses, conditions, specifications and other details of the contract and the bidder shall not plead ignorance of any of those as excuse in case of complaint against or on rejection of supplies tendered by him or with a view either to ask for encashment of any rates agreed to in the contract or to evading any of his obligations under the contract.

**6.30 Limitations of Liability**

Further, bidders commulative liability for its obligations under contract shall not exceed the total contract value.

\* \* \* \* \*

## ANNEXURES

**Annexure 1**  
**List of jails**

Sr. No.	Name of Jail	Walled up area	Sketch Plan area of visitors rooms	Length of Kotmoka/ Perimeters wall
17.	C.J. Ambala	195779 sq. Yrds	780 sq. Yrds	4518 Feet
18.	C.J. Hisar	1337.73 sq. mtr		1463.04 mtr.
19.	D.J. Gurgaon			1810 mtr.
20.	D.J. Karnal	41 acre		1600 mtr.
21.	D.J. Kurukshetra	8.18 acre		762 mtr.
22.	D.J. Sonapat	735.93 mtr.		2414 feet
23.	D.J. Yamuna Nagar	19848789 sq. mtr	441 Sq. Mtr.	24195 sq. mtr.
24.	D.J. Jind	9 acre		12 acre
25.	D.J. Bhiwani	63133 sq. feet		3355 feet
26.	D.J. Sirsa	669.6 mtrs		669 mtrs.
27.	D.J. Kaithal	270232.50 sq. feet	671.87 Sq. feet	2175 Rft.
28.	D.J. Narnaul	3214 feet		2230 feet
29.	D.J. Faridabad	32268 sq. mtr		6250 Sq. Mtr.
30.	B.I. & J. Jail Hisar	42762 Sq. mtr		827.17 Mtr.
31.	Jajjhar			
32.	Rohtak			

(to be submitted by successful bidder)

**Annexure –II**  
**Format of Performance Bank Guarantee in favour of HARTRON**

- (i) In consideration of Haryana State Electronics Development Corporation Ltd. (HARTRON) and having its Headquarter at SCO 111-113, Sector 17B, Chandigarh, which expression unless the context otherwise requires, shall include its successors and permitted assigns (the "HARTRON") having agreed to accept from [ ] (the name of the Successful bidder) a company incorporated, organized and subsisting under the Companies Act, 1956 (1 of 1956) and having its registered office at [ ..] which expression unless the context otherwise requires, shall include its successors and permitted assigns (the "Successful bidder") under the terms and conditions of an agreement dated the [.....] day of [.....] between the HARTRON and the Successful bidder for the Supply, Installation & Commissioning and facility Management of Wireless CCTV Surveillance system For Haryana Prisons on BOOT model as specified in the RFP Document for the same. Security deposit for the due fulfillment by the Successful bidder of the terms and conditions contained in the Contract Agreement on production of an interest free bank guarantee ("Performance Bank Guarantee") of 10% of the total project value of Rs. \_\_\_\_\_ ( \_\_\_\_\_ rupees only) amounting to Rs. \_\_\_\_\_ ( \_\_\_\_\_ rupees only) in favour of the HARTRON to be renewed annually up to the currency of the contract Agreement. The guarantee amount for such annual renewal shall be calculated on the basis of the balance amount of the total project cost.
- (ii) We, [ ] (name of the, Bank) do hereby guarantee and undertake to indemnify and pay and keep indemnified the HARTRON in terms of the Contract Agreement to the extent of this Bank Guarantee value of Rs. \_\_\_\_\_ ( \_\_\_\_\_ rupees only).
- (iii) We, [ ] (name of the Bank) further agree that if a demand is made by the HARTRON for honoring the Performance Bank Guarantee we, [ ] (name of the Bank) having no right of decline to cash the same for any reason whatsoever. The fact that there is a dispute between the HARTRON and the Successful bidder is no ground for us [ ] (name of the Bank) to decline to honour the Performance Bank Guarantee.
- (iv) We, [ ] (name of the Bank) further agree that a mere demand by the HARTRON is sufficient for us [ ] (name of the Bank) to pay the amount covered by the Performance Bank Guarantee without reference to the Successful bidder and any protest by the Successful

bidder cannot be valid for us [ ] (name of the Bank) to decline payment to the HARTRON.

- (v) We, [ ] (name of the Bank) further agree that the HARTRON shall have the fullest liberty, without affecting in any manner our obligations hereunder to vary any of the terms and conditions of the Contract Agreement or to extend time of performance by the Successful bidder from time to time or to postpone for any time or from time to time, any of the powers exercisable by the HARTRON against the Successful bidder and to forbear or enforce any of the terms and conditions relating to the Contract Agreement and we shall not be relieved from our liability by reasons of any such variation or extension being granted to the Successful bidder or for any forbearance, act or omission on the part of the HARTRON or any indulgence by the HARTRON to the Successful bidder or any such matter or thing whatsoever which under the law relating to sureties would but for this provision have effect of so relieving us [ ] (name of the Bank).
- (vi) We [ ] (name of the Bank) lastly undertake not to revoke this Guarantee during its currency except with the previous consent of the HARTRON in writing.

DATED THE [ ] DAY OF [ ] Signatures \_\_\_\_\_  
Name \_\_\_\_\_  
Designation \_\_\_\_\_  
For [Name of the Bank]  
(Seal of the Bank)

\*\*\*\*\*

## PROFORMAS

(To be enclosed with pre-qualification bid).

**Proforma 1**  
**BID PROPOSAL SHEET**

Bidder's Proposal Reference No. and Date	:		
Bidder's Name and Address	:		
	:		
		Tel. No.	Fax No.
Bidders Correspondence address	:		
	:		
		Tel. No.	Fax No.
Name of contact Person	:		
Designation	:		
Telephone No (s)	:		
Fax No (s)	:		
Mobile No	:		
Email ID	:		

**To,**

Managing Director  
HARTRON  
SCO 111-113  
Sector 17 B  
Chandigarh 160017

**Subject : Proposal for Supply, Installation & Commissioning and Project Management of wireless CCTV surveillance system for respective jails based on the Build Own Operate and Transfer (BOOT) model for five years.**

Dear Sir,

1. We, M/s \_\_\_\_\_, having read and examined in detail the specifications, requirements as mentioned in the RFP do hereby propose for Supply, Installation & Commissioning and facility Management of wireless CCTV

surveillance system for respective jails based on the Build Own Operate and Transfer (BOOT) model for five years.

## **2. PRICE AND VALIDITY**

All the prices mentioned in our proposal are in accordance with the terms as specified in bidding documents. All the prices and other terms and conditions of this proposal are valid for a period of 120 days from the opening of the commercial bid or six months from the last date of submission of the RFP, which ever is later.

## **3. EARNEST MONEY**

We have enclosed the earnest money in the form of Bank Draft amounting to **Rs. 5.0 Lakhs**. It is liable to be forfeited in accordance with the provisions of RFP document.

## **4. ASSURANCE**

We declare that all the services shall be performed strictly in accordance with the technical specifications and other terms and conditions covered in RFP document.

## **5. BID PRICING**

We further declare that the prices stated in our proposal are in accordance with your terms & conditions in the bidding document.

## **6. QUALIFYING DATA**

We confirm having submitted the qualifying data as required by you in your RFP document. In case you require any further information/ documentary proof in this regard before evaluation of our bid, we agree to furnish the same, in time, to your satisfaction.

7. We hereby declare that in case the contract is awarded to us, we shall submit the Bank Guarantee as per terms of RFP document.
8. We hereby declare that our proposal is made in good faith, without collusion or fraud and the information contained in the proposal is true and correct to the best of our knowledge & belief. We further declare that we have read the provisions of this RFP and confirmed that these are acceptable to us.
9. Bid submitted by us is properly prepared and sealed so as to prevent any subsequent alteration and replacement.
10. We understand that you are not bound to accept the lowest or any bid by you.

Thanking you,

Yours faithfully,

**(Authorised Signatory)**

Date:

Name:

Place:

Designation:

Business Address:

Seal of the company:

(To be enclosed with Pre Qualifying Bid)

**PROFORMA – 2**  
**PARTICULARS OF BIDDERS AND MANUFACTURERS**

FOR RFP NO. \_\_\_\_\_

1. Name of the Bidder				
2. Address of the Bidder				
	Tel.		Fax	
3. Year of establishment (Enclose certificate of incorporation under company act 1956 )				
4. Bidder's proposal number and date				
5. Name, Designation and address of the officer to whom all references shall be made regarding this RFP				
	Tel:		Mobile:	
	Fax:		Email:	
6. Annual turnover of the firm for the last 3 successive years (in Rs.)	Year	Turn over	Profit bid	Pg. no of
	2007-2008			
	2008-2009			
	2009-2010			
7. Details of Draft for Earnest money deposited	Draft No.			
	Bank Name:			
8. PAN no. of the company				

Signature \_\_\_\_\_  
 Name \_\_\_\_\_  
 Designation \_\_\_\_\_  
 Date \_\_\_\_\_  
 Company seal \_\_\_\_\_

(To be enclosed with Pre Qualifying Bid)

**PROFORMA 3**  
**MANUFACTURER WARRANTY**

We, M/S ----- warrant that everything to be supplied by us hereunder shall be brand new, free from all encumbrances, defects and faults in material. Workmanship and manufacturing shall be of the highest grade and quality and consistent with the established and generally accepted standards. Materials of the type ordered shall be in full conformity with the specifications, drawings or samples, if any, and shall operate properly.

We, M/S----- also undertake that in case any item supplied by us found to be defected, faulty, or used at any stage, it shall be replaced by us at our cost.

Signature of the Witness

Signature of the Tenderer

Name

Name

Seal

Date

(To be enclosed with Prequalification bid on the official letter head of the bidding company)

**PROFORMA - 4**

**UNDERTAKING FOR MANAGEMENT**

We, M/S ----- undertake to Supply, Installation & Commissioning and facility Management of wireless CCTV surveillance system for respective jails based on the Build Own Operate and Transfer (BOOT) model for five years.

We, M/S ----- further undertake that we will manage equipment /infrastructure supplied, installed and for a period of five years as per the terms and conditions mentioned in the RFP document. The period of this facility management will begin after the clearance of final acceptance test of the project and with effect from the date on which acceptance certificate for the successful commissioning of the system is issued.

We M/s \_\_\_\_\_ also agree to extend the facility management period for third, year as per the terms and conditions mentioned in the RFP Document if required by the tenderer.

We M/s \_\_\_\_\_ also agree to hand over the supplied, installed and configured equipment/ infrastructure in the good running condition with same or improved specifications after the completion of the facility management period in accordance to the clause no.6.18 of this RFP.

Signature of the Witness

Name

Address

Signature of the Tenderer

Name

Address

Seal

(To be enclosed with Technical Bid on the official letter head of the bidding company)

**PROFORMA - 5**

**UNDERTAKING FOR NETWORK INSTALLED IN COMPLETE RESPECT,  
TRAINING, ETC.**

We, M/S ----- undertake

1. That we undertake that the equipment installed and commissioned at all the site shall be complete in all respects adhering to the requirements specified in the RFP for end to end implementation of the services.
2. that we will accordingly train the manpower of Prison department as per the scope of training under section II of RFP document, so that the concerned officers/officials of respective departments/ Haryana Prison can handle the system, once the project management period is over.

Signature of the Witness

Signature of the Tenderer

Name

Name

Address

Address

Seal

(To be enclosed with Prequalification bid)

**PROFORMA – 6**  
**AFFIDAVIT**  
**(MANUFACTURER'S AUTHORIZATION CERTIFICATE)**

From

\_\_\_\_\_  
\_\_\_\_\_

To

Managing Director,  
HARTRON, SCO 111-113  
Sector 17-B, Chandigarh

\_\_\_\_\_ do hereby solemnly affirm and declare as under:-

- (i) That this is to certify that M/S \_\_\_\_\_ is our authorized dealer/distributor/agent and he is authorized to submit tender/quote the rates in the State of Haryana against RFP enquiry No. \_\_\_\_\_ due on \_\_\_\_\_ and to supply the material in original manufactured by us.
- (ii) That we shall have full responsibility of satisfactory supplies against the supply order/rate contract.
- (iii) That I am fully authorized to give this affidavit on behalf of M/s \_\_\_\_\_ and the power of attorney has been executed in my favour (Attested copy enclosed).

Deponent

(To be enclosed with Prequalification bid on the official letter head of the bidding company)

**PROFORMA 7**

**Indemnification from proprietary rights**

From

\_\_\_\_\_  
\_\_\_\_\_

To

Managing Director,  
HARTRON, SCO 111-113  
Sector 17-B, Chandigarh

We M/s \_\_\_\_\_ indemnify Hartron and prison department against all third party claims of infringement of patent, copyright, trademark and trade designs arising from use of the goods or any part thereof in India.

Signature of the Witness

Name

Address

Signature of the Tenderer

Name

Address

Seal

(To be enclosed with Prequalification bid on the official letter head of the bidding company)

**PROFORMA 8**  
**Indemnification from patent rights**

From

\_\_\_\_\_  
\_\_\_\_\_

To

Managing Director,  
HARTRON, SCO 111-113  
Sector 17-B, Chandigarh

We M/s \_\_\_\_\_ indemnify Hartron and Prison department against all third-party claims of infringement of patent, trademark or industrial design and intellectual property rights arising from the use of the Goods or any part thereof.

Signature of the Witness

Name

Address

Signature of the Tenderer

Name

Address

Seal

**Proforma – 9****BID FORM****(To be submitted separately for each jail in Technical Bid proposal )**

Date: \_\_\_/\_\_\_/\_\_\_

**Managing Director**  
**Haryana State Electronics Dev. Corpn. Ltd., (HARTRON)**  
**SCO 111-113, Sector 17-B,**  
**Chandigarh.**

Having examined the Bidding Documents of Tender HARTRON.Proj./CCTV-....., we, the undersigned, offer to Supply, Installation & Commissioning and Project Management of wireless CCTV surveillance system for respective jails based on the Build Own Operate and Transfer (BOOT) model for five years in conformity with this tender document for same as may be ascertained in accordance with the Schedule of Prices provided in the Commercial Bid.

Sl. No.	Name of the Item	QTY	Model	Make
1	<b>Required Field Equipments</b>			
2	<b>Camera</b>			
2 a)	Outdoor Fixed Box IP Camera with varifocal lens			
2 b)	Outdoor PTZ Cameras with varifocal lens			
3	<b>Wireless Equipments for Camera Connectivity</b>			
3 a)	Wireless Access Points			
3b)	Wireless CPE			
4	<b>Control Room Equipments in Jail</b>			
4 a)	Server for Live View and Video Analytics for all cameras. Single server shall support minimum 9 cameras for simultaneous Video Analytics and Live View for 720p 25/30 fps stream.			
4 b)	Management & Network Video Recording Server for all the cameras with minimum resolution 4CIF 25/30fps (with monitor).			
4 c)	Management Client PC for configuration of Cameras, Video Analytics applications.			
4 d)	Live View and Video Management Software license for the quoted quantity of the cameras			
4 e)	Recording License for the quoted quantity of the cameras			
4 f)	Video Analytic License for the quoted quantity of the cameras			
4 g)	24 Port Network Switch			
4 h)	Digital Keyboard/Joystick for controlling the PTZ Cameras			
4 i)	32" Monitors for Live View (9 Cameras for one Monitor)			

4 j)	Racks for Mounting Servers, network devices and other equipments in control room			
5	<b>Network Active Components</b>			
5 a)	Layer 2 switch with 24 RJ-45 ports of 100/1000 Mbps and two uplink Ports, one for Fiber and one for Copper, to be installed in each control room.			
6	<b>Network Passive Components</b>			
6 a)	Passive components comprising of connector, patch cords, RJ-45 cable/connectors, racks, mounting, etc. required for Cameras	LOT		
6 b)	Passive components comprising of connector, patch cords, RJ-45 cable/connectors, racks, mounting, etc. required for 23 Control Room	LOT		
7	<b>UPS</b>			
7 a)	UPS for Control Room Equipments with four hour back up.			
7 b)	UPS for cameras with one hour back up.			
8	<b>Power System for Camera Locations and Access Point Locations</b>			
8 a)	Power Back Up with Solar System/UPS and related Accessories			
9	<b>Housing Units (UPS, Batteries and Solar Power/UPS Equipments)</b>			
9 a)	Outdoor IP66 rated housing at each camera location			
9 b)	Outdoor IP66 rated housing at each Access Point location			

We undertake, if our bid is accepted, to complete the supply of equipment and their related accessories as the case may be within the stipulated time frame of one month unless otherwise specified in the contract agreement to be executed from the date of receipt of your Notification of Award.

We agree to abide by this bid for a period of 180 days from the date fixed for bid opening and it shall remain binding upon us and may be accepted at any time before expiration of that period. Until a formal contract is prepared and executed, this bid, together with your written acceptance thereof and your notification of award, shall constitute a binding Contract between us.

We have enclosed demand draft no----- Dated ----- drawn in favour of HARTRON for .....as EMD.

We understand that you are not bound to accept the lowest or any bid you may receive. We also understand that you have the right to vary the quantities.

Dated \_\_\_\_\_ Day of \_\_\_\_\_ 2010

& Seal

Signature

(in the  
Capacity of)

Only Authorized to sign bid for and on behalf of \_\_\_\_\_

(To be enclosed with technical bid)

**PROFORMA 10**  
**TECHNICAL DEVIATIONS**

**Subject:** **Technical Deviations for carrying out** Supply, Installation & Commissioning and Project Management of wireless CCTV surveillance system for respective jails based on the Build Own Operate and Transfer (BOOT) model for five years.

Dear Sir,

---

<b>Sr. No.</b>	<b>Clause No.</b>	<b>Page No.</b>	<b>Statement of deviations and variations</b>
----------------	-------------------	-----------------	---

---

---

**Date**

**Signature**

**Name**

**Place**

**Seal**

(To be enclosed with commercial bid)

**PROFORMA 11**  
**FINANCIAL DEVIATIONS**

**Subject:** Financial Deviations for carrying out Supply, Installation & Commissioning and Project Management of wireless CCTV surveillance system for respective jails based on the Build Own Operate and Transfer (BOOT) model for five years

Dear Sir,

---

Sr. No.	Clause No.	Page No.	Statement of deviations and variations
------------	---------------	-------------	---

---

---

**Date**

**Signature**

**Name**

**Place**

**Seal**

**Proforma – 12**  
(To be submitted separately for each jail with commercial Bid)  
Breakup cost

Sl. No.	Name of the Item	QTY	Model	Make	Unit Cost	Total Cost (Exclusive of Taxes)	Sales Tax/ VAT/ Any other Taxes/ Govt. Duty (in Rs.)	Total Cost (Inclusive of Taxes)
1	<b>Required Equipments</b> <b>Field</b>							
2	<b>Camera</b>							
2 a)	Outdoor Fixed Box IP Camera with varifocal lens							
2 b)	Outdoor PTZ Cameras with varifocal lens							
3	<b>Wireless Equipments for Camera Connectivity</b>							
3 a)	Wireless Access Points							
3b)	Wireless CPE							
4	<b>Control Room Equipments in Jail</b>							
4 a)	Server for Live View and Video Analytics for all cameras. Single server shall support minimum 9 cameras for simultaneous Video Analytics and Live View for 720p 25/30 fps stream.							
4 b)	Management & Network Video Recording Server for all the cameras with minimum resolution 4CIF 25/30fps (with monitor).							
4 c)	Management Client PC for configuration of Cameras, Video Analytics applications.							
4 d)	Live View and Video Management Software license for the quoted quantity of the cameras							
4 e)	Recording License for the quoted quantity of the cameras							
4 f)	Video Analytic License for the quoted quantity of the cameras							
4 g)	24 Port Network Switch							
4 h)	Digital Keyboard/joystick for controlling the PTZ Cameras							
4 i)	32" Monitors for Live View (9 Cameras for one Monitor)							
4 j)	Racks for Mounting Servers, network devices and other equipments in control room							

5	<b>Network Components Active</b>							
5 a)	Layer 2 switch with 24 RJ-45 ports of 100/1000 Mbps and two uplink Ports, one for Fiber and one for Copper, to be installed in each control room.							
6	<b>Network Components Passive</b>							
6 a)	Passive components comprising of connector, patch cords, RJ-45 cable/connectors, racks, mounting, etc. required for Cameras	LOT						
6 b)	Passive components comprising of connector, patch cords, RJ-45 cable/connectors, racks, mounting, etc. required for 23 Control Room	LOT						
7	<b>UPS</b>							
7 a)	UPS for Control Room Equipments with four hour back up							
7 b)	UPS for camera with one hour back up.							
8	<b>Power System for Camera Locations and Access Point Locations</b>							
8 a)	Power Back Up with Solar System/UPS and related Accessories							
9	<b>Housing Units (UPS, Batteries and Solar Power/UPS Equipments)</b>							
9 a)	Outdoor IP66 rated housing at each camera location							
9 b)	Outdoor IP66 rated housing at each Access Point location							
10	<b>Manpower</b>							
10 a)	Two (2) Technical Engineers for each jail to operate and maintain the surveillance system							
AMC for two years on the net value of the equipment after the expiry of warranty of five years								
AMC for 6 <sup>h</sup> year								
AMC for 7 <sup>th</sup> year								
Total								

Signature of Bidder

Full Name: \_\_\_\_\_

Full address and telephone no.:

---

**PROFORMA 13**

To be enclosed with commercial bid  
Quarterly release of payment

To

**Managing Director**  
**Haryana State Electronics Dev. Corpn. Ltd., (HARTRON)**  
**SCO 111-113, Sector 17-B,**  
**Chandigarh.**

**Ref: Tender No. Hartron/Proj/CCTV HARYANA JAIL/2010-11**

**We declare:**

We M/s \_\_\_\_\_ hereby offer to Supply, Installation & Commissioning, operation, maintenance and facility Management of wireless CCTV surveillance system for respective jails based on the Build Own Operate and Transfer (BOOT) model for five years as per the following

Sr. No.	Name of Jail	Quarterly release of payment to be paid in equal 20 installments.	
		Unit cost	Total
1.	Supply, Installation, commissioning, operation and maintenance, facility management of CCTV system at C J. Ambala		
2.	Supply, Installation, commissioning, operation and maintenance, facility management of CCTV system at C.J. Hisar		
3.	Supply, Installation, commissioning, operation and maintenance, facility management of CCTV system at D.J. Gurgaon		
4.	Supply, Installation, commissioning, operation and maintenance, facility management of CCTV system at D.J. Karnal		
5.	Supply, Installation, commissioning, operation and maintenance, facility management of CCTV system at D.J. Kurukshetra		
6.	Supply, Installation, commissioning, operation and maintenance, facility management of CCTV system at D.J. Sonapat		
7.	Supply, Installation, commissioning,		

	operation and maintenance, facility management of CCTV system at D.J. Yamuna Nagar		
8.	Supply, Installation, commissioning, operation and maintenance, facility management of CCTV system at D.J. Jind		
9.	Supply, Installation, commissioning, operation and maintenance, facility management of CCTV system at D.J. Bhiwani		
10.	Supply, Installation, commissioning, operation and maintenance, facility management of CCTV system at D.J. Sirsa		
11.	Supply, Installation, commissioning, operation and maintenance, facility management of CCTV system at D.J. Kaithal		
12.	Supply, Installation, commissioning, operation and maintenance, facility management of CCTV system at D.J. Narnaul		
13.	Supply, Installation, commissioning, operation and maintenance, facility management of CCTV system at D.J. Faridabad		
14.	Supply, Installation, commissioning, operation and maintenance, facility management of CCTV system at B.I. & J. Jail Hisar		
15.	Supply, Installation, commissioning, operation and maintenance, facility management of CCTV system at Jail Jajjhar		
16.	Supply, Installation, commissioning, operation and maintenance, facility management of CCTV system at Jail Rohtak		
17.	Grand Total		
18.	AMC cost for 6 <sup>th</sup> year for all jails		
19.	AMC cost for 7 <sup>th</sup> year for all jails		

Period of Delivery: We do hereby undertake, that in the event of acceptance of our bid, the supply will be completed unless other wise specified as per the delivery schedule mentioned under the conditions with the tender form and the quantities for each type of device finalized by HARTRON in consultation with.....

Terms of Delivery: The prices quoted for each type device are inclusive of current Excise Duty, Freight, Insurance, Customs, etc. as well as without Customs in case of Custom exemption certificate.

We agree to abide by our offer for a period of 180 days from the date fixed for opening of the Pre-Qualification cum Technical bid and that we shall remain bound by a communication of acceptance within that time.

We hereby certify that we have read and understood the terms and conditions of the tender and the conditions of the Contract applicable to the tenderer and we do hereby undertake to supply as per these terms and conditions.

We do hereby undertake that until a formal Contract is prepared and executed, this bid, together with your written acceptance thereof and placement of letter of intent awarding the Contract shall constitute a binding Contract between us.

**Dated: this \_\_\_\_\_ day of \_\_\_\_\_ 2010**

**Signature of Bidder**

Full Name: \_\_\_\_\_

Full address: \_\_\_\_\_

\_\_\_\_\_

\_\_\_\_\_

Telephone No. \_\_\_\_\_

Fax no \_\_\_\_\_

E-mail: \_\_\_\_\_

**Details of enclosures**

**PROFORMA 14**

**DECLARATION BY THE BIDDER**

**(To be enclosed with pre qualification Bid)**

NAME OF THE BIDDER: M/s\_\_\_\_\_

The bidder is requested to sign and affix their seal on each page of this document and submit this duly signed original RFP document with pre-qualification bid in respective cover without fail.

The bidder is also requested to give the following declaration as per the format.

We M/s \_\_\_\_\_ have gone through the terms and conditions and will abide by them as laid down vide pages from 1 to \_\_\_\_ (RFP containing Pre-qualification, Technical, Commercial Bid and all relevant Annexures and formats enclosed)

We M/s \_\_\_\_\_ hereby confirm that our firm has not been blacklisted by any State Government / Central Government. We M/s \_\_\_\_\_ further confirm that our firm has no legal case pending in any of the courts for winding up the company.

We M/s \_\_\_\_\_ hereby declare that the particulars furnished by us in this offer are true to the best of our knowledge and we further understand and accept that, if at any stage the information furnished is found to be incorrect or false, we are liable for disqualification from this tender and also is liable for any penal action that may arise due to the above.

Date:  
Place:

Signature :  
Name :  
Designation :  
Seal of Bidder: